

CHICOPEE ELECTRIC LIGHT

Customer Service Handbook



It's Your Power.

TABLE OF CONTENTS

CEL Statement of Purpose	1
Terms and Conditions	1
Chapter 1 Introduction	
1.1 Purpose “CEL Customer Service Handbook”	6
1.2 Residential Service	6
1.3 Temporary Service	7
1.4 Business Service	7
1.4.1 Primary Voltage Service	7
Chapter 2 Overhead Services	
2.1 Typical Overhead Service	8
2.2 Typical Overhead Installation	8
2.3 Overhead Line Clearances	8
2.4 Horizontal Clearance	9
2.5 Checklist For Installing Overhead Service	9
2.6 Service Mast, Meter	10
2.7 Temporary Overhead Service Meter Post	10
2.8 Overhead Service, Meter Pole	11
Chapter 3 Underground Services	
3.1 Checklist For Installing Underground Service	22
3.2 Locating Underground Utilities	23
3.3 Secondary Residential and Small Business Services	23
3.3.1 Trenching	24
3.3.2 Single Use Trench	25
3.3.3 Joint Use Trench	25
3.3.4 Direct-Burial Conductors	25
3.3.5 Conduit Size	25
3.3.6 Underground Conduit	25
3.3.7 Underground Service, Meter	26

TABLE OF CONTENTS

3.3.8	Underground Service, Meter with Pedestal	26
3.3.9	Temporary Underground Service, Meter Post	26
3.4	Business, Industrial, or Multi-Family Residential Building Services	26
3.4.1	Safety & Work Clearances Around Transformers & Padmount	26
3.4.2	Guard Posts	27
3.4.3	Pad Mounted Transformer Installation	27
3.4.4	Dedicated Pole Mounted Transformer Installation	28
3.5	CEL Underground Distribution Standard Drawings	28

Chapter 4 Meter Installations

4.1	Locating the Meter	45
4.1.1	Meter Locations	45
4.1.2	Meters Should Not Be Located at the Following Locations	45
4.1.3	Meters Located Inside the Electrical Room	46
4.2	Duct Box	46
4.3	Clearances Around the Meter	47
4.4	Installation for an Apartment Building	47
4.5	Installation for an Office Building	48
4.6	Metering to Multiple Mobil Homes	48
4.7	General Requirements for Meter Sockets	48
4.7.1	Sockets for Residential and Temporary Services	48
4.8	Grounding a Meter Socket	48
4.9	Meter Installation Tips	49
4.9.1	Cable Runs	49
4.9.2	Labeling	49
4.9.3	Protection	49
4.10	Direct-Connect Meters	50
4.11	Current Transformer Metering	50
4.11.1	Current Transformer Cabinet	51
4.11.2	Meter Socket, Enclosure and Conduit	51

TABLE OF CONTENTS

4.11.3	Conduit	51
4.11.4	Mounting Base for Current Transformer, Single Phase Services	52
4.11.5	Mounting Base for Current Transformer, Three Phase Services	52
4.12	Switchboard Metering	52
4.13	Off Peak Metering	53
4.14	Rental Hot Water Tank Requirements	55
	Water Heater Rental Agreement (Sample)	56
Chapter 5	Service Fee Information and Customer Forms	
	Service Fee Information	73
	Light Options (Security & Contract Lighting Rental Program)	74
	CEL Rate Schedule	76
	CEL Service and Meter Location Form (Sample)	78
	Application for Temporary Service (Sample)	79
	Residential Application for Service (Sample)	80
	Commercial / Industrial Application for Service (Sample)	81
	CEL Sample Bill	83
Glossary		84

CEL STATEMENT OF PURPOSE

“As a consumer owned utility, our purpose is to provide reliable, high quality services to the community at the lowest cost consistent with ensuring resources for proper maintenance, modernization and meeting the demands for future expansion. It is also our purpose to strive for excellence in our daily operations and to provide a safe and productive workplace in which all employees are treated with equity and respect.”

TERMS AND CONDITIONS

Effective as of June 1, 2000

1. General:

This Terms and Conditions Statement has been established to convey the conditions that you, as a Customer, agree to when requesting service from CEL. The benefits and obligations of this Agreement will commence on the day that you, as the Customer, are connected to CEL's service and will inure to and be binding upon the successors and assigns, survivors and executors or administrators of the original parties. CEL reserves the right to revise, amend, supercede, supplement or change these Terms and Conditions from time to time in accordance with the Department of Public Utilities (“DPU”) standards. In the events that any of the Terms and Conditions is in conflict with any applicable DPU rule or regulation, DPU rules and regulations shall govern.

2. Application:

Service shall not be supplied unless and until the Customer completes an “Application for Service”, and any balances outstanding are paid in full. The Application must be accurate, true, complete and signed by the Customer of Record. All Customers' electrical needs present and future, if known, should be stated at the time of the application.

3. Deposit:

A deposit may be required on any commercial or residential account. Deposits shall be determined by Customer's credit standing as is reported by the national credit bureau. Deposits may be waived if the Customer provides CEL with proof that the Customer is the owner of the property for which service is requested. CEL reserves the right to request a deposit at any time, and from time to time, on any account that does not remain in good standing.

Interest is payable annually on all deposits which are retained longer than six (6) months at a rate that is at or above such rate specified by applicable laws and regulations. Such rate may be credited to a Customer's account. Refunds on the deposits shall be returned for residential services if after twenty-four (24) months of service Customer has paid all bills for usage in the twenty-four (24) month period from the date of deposit and without leaving such bills unpaid within forty-five (45) days of receipt. Commercial Deposits remain with the account until closed, unless otherwise stated by CEL.

All deposits shall be due and paid before service will be provided.

4. Metering:

For the purpose of determining the amount of electricity used, a meter or meters will be installed and maintained by CEL on the Customer's premises. All meters, wires and other apparatus furnished by CEL are and shall remain sole and exclusive property of CEL. Customer agrees that the wiring upon the premises of the Customers to which service will be connected shall be installed and maintained by Customer in accordance with the requirements of the National Electrical Code and all requirements of the City of Chicopee.

CEL or its authorized agent shall have access to the Customer's premises at all reasonable times to install, read, inspect, test, operate, maintain, repair, or remove its equipment, to discontinue service, to determine the rate or rates for the Customer's electric service, or for any other purpose reasonably related to the provision of electric service.

The customer shall not injure, interfere with, destroy or tamper with any meter or other property of CEL. The Customer shall be responsible for the care and protection of any of CEL's property located or installed on the Customer's premises and shall not permit anyone but CEL or its authorized representatives to have access to such property. CEL's property, machinery or equipment shall not be handled or operated by anyone other than CEL or its authorized representatives without the express written consent of CEL. CEL will lock or seal all enclosures containing meters or metering equipment, and no person, except an employee or duly authorized agent of CEL shall be permitted to, in any way, change or modify CEL's meters or other equipment, and no seals or locks shall be permitted to be removed without the written authorization of CEL. Customer shall indemnify and hold CEL harmless, should any violations of these provisions result in injury, death or damage to persons or property.

Subject to the provisions of Massachusetts General Law, Chapter 164 and applicable DPU regulations, when a meter is found to be tampered with, service to that meter will be disconnected. To have service restored, the Customer shall be required to pay charges (related to disconnection, damages and investigation) and may be required to pay an additional security deposit. Service shall not be restored until Customer has paid all charges in full. Instances of tampering with meters will be reported to the appropriate authorities. Customer may also be subject to criminal and civil penalties pursuant to the Massachusetts General Laws.

5. Meter Reading/Bills:

A bill based on an actual or estimated reading of CEL's metering equipment shall be rendered monthly, payable upon receipt. When a Customer is serviced through more than one meter, each meter will be considered separately.

If CEL cannot obtain a meter reading, it shall render an estimated bill, provided CEL has not rendered an estimated bill for the billing period prior to that for which the estimate is made, except in the case where circumstances reasonably beyond the control of CEL prevent it from obtaining an actual meter reading. Subject to the provisions of Massachusetts General Laws, Chapter 164 and applicable DPU regulations, if any Customer, directly or indirectly, prevents or hinders any such employee or agent of CEL from entering such premises for the purpose of making such examination, CEL may pursuant to M.G.L. c. 164, & 116 make a complaint to any court or magistrate authorized to issue criminal process.

6. Classification:

CEL determines a Customer's appropriate rate based on information provided by Customer at the time of application for service. The rates are updated to provide each Customer the most advantageous rate available. It is the Customer's responsibility to assure itself that it is on a rate most advantageous to itself. Customer should promptly notify CEL of any change in circumstances, which may qualify Customer for a more advantageous rate.

7. Discontinuance of Service/Nonpayment:

- A. Unsafe wiring, fraud, or theft:** CEL may discontinue service without notice if a Customer's wiring is found to be in a dangerous or unsafe condition or as is necessary to protect CEL from fraud or theft. Service shall not be resumed until the City of Chicopee Wiring Inspector certifies to CEL that any dangerous or unsafe condition has been corrected and all wiring is in accordance with the applicable laws and regulations.
- B. Unsatisfactory Equipment:** CEL may discontinue service and remove its equipment if, in its judgment, the equipment has become unsatisfactory for further service due to deterioration, civil commotion, vandalism, state of war, explosion, fire, storm, flood, lightning, or any other cause reasonably beyond CEL's control. Customer may be required to pay the applicable charges for the remainder, in any, of the applicable term of service.
- C. Access to Premises:** Subject to the provisions of Massachusetts General Laws, Chapter 164 and applicable DPU regulations, if any Customer, directly or indirectly, prevents or hinders any employee or agent of CEL from entering a premises for the purposes of making an examination, removing meters for the purpose of work relating to supply or regulation of supply, or for the purpose of ascertaining the quantity of electricity consumed or supplied, such Customer shall be subject to termination of services.
- D. Non-Payment of Charges:** If a Customer defaults on payments due to CEL, service may be discontinued in accordance with DPU Regulations 220 CMR 25.00-25.05, to the extent that such regulation is applicable. CEL shall not restore service until the Customer has:
 - 1. Made an application for service and paid all bills due for service previously furnished; and
 - 2. Made a satisfactory deposit to insure payment of future bills; and
 - 3. Paid the costs of reconnection of the premises for which service has been discontinued.

CEL shall not be responsible or liable for loss or damage to any person or property resulting from disconnection of service regardless of whether service is disconnected at the Customer's request or by CEL and regardless of whether the Customer owns the premises to which service has been supplied.

In the event of an actual or threatened shortage of energy supplies or resources, CEL may, in its sole discretion, curtail, allocate, or interrupt electric service to any Customer or Customers if CEL determines, in its sole discretion, any part of the generation, transmission or distribution systems CEL utilizes may be threatened by a condition that may affect its ability to continue to supply electric service of sufficient quality, quantity and reliability.

Although CEL will make every effort to make necessary repairs and changes to its system without having to suspend the delivery of service, CEL reserves the right to suspend service in order to make repairs or changes.

8. Collection:

The Customer is responsible for any collection costs, including court costs and attorneys' fees associated with any unpaid balances, meter tampering, theft of services, fraud or otherwise.

9. Limitations of Liability:

The City of Chicopee, CEL, and all of their respective agents and employees shall be afforded the maximum exemption of limitations of liability available under applicable laws and regulations arising on account of their actions or omissions relating directly or indirectly any provision of electrical service. Without limiting the generality of the foregoing, and except to the extent otherwise expressly provided in Massachusetts General Laws, Chapter 258:

Neither the City of Chicopee, nor CEL nor any of their respective agents or employees shall be liable to any person:

- a. For any failure by CEL to supply electric service or for any interruption in the supply of or delay in the restoration of such service.
- b. For any damage to any person (including personal injury or death) or any damage to any property, directly or indirectly, arising as a result of the electric service provided by CEL, the presence of CEL's apparatus or equipment on any Customer's premises, or any acts of omissions of CEL.
- c. For discontinuance of electrical service to any Customer who fails to comply with, or perform any of the Customer's obligations under these Terms and Conditions, applicable laws and regulations, or other agreements with CEL
- d. The discontinuance of electrical service if any equipment or apparatus of any Customer interferes with service provided by CEL or with the delivery of service to other Customers or interferes with the integrity of CEL' System.
- e. For any variation, or interruption in electrical service including without limitation, any such variation or interruption because of abnormal or reduced voltage, emergency load reduction programs, blackouts, or any causes beyond the reasonable control of CEL, including, but not limited to, accidents, war, civil commotion, acts of GOD, labor difficulties, acts of Customers, or acts of any public authority.

10. Inspections

Approval by the City of Chicopee Wiring Inspector for electric service is required before service can be initiated to any new, or newly wired or rewired building, structure or residence.

11. METER TAMPERING AND DIVERSION

As per the GENERAL LAWS OF MASSACHUSETTS, PART 1. ADMINISTRATION OF THE GOVERNMENT, TITLE XXII. CORPORATIONS, CHAPTER 164, MANUFACTURE AND SALE OF GAS AND ELECTRICITY, INSPECTION OF GAS AND METERS, SECTION 127 & SECTION 127A, DESTRUCTION OF OR TAMPERING WITH, ELECTRIC OR GAS LINES, METERS, ETC.; THEFT OF ELECTRICITY OR GAS states:

Section 127:

Whoever unlawfully and with intent to avoid payment by himself or another person for a prospective or previously rendered service the charge or compensation for which is measured

by a meter or other mechanical device injures or destroys, or suffers to be injured or destroyed, any meter, pipe, conduit, wire, line, pole, lamp or other apparatus belonging to a corporation engaged in the manufacture or sale of electricity or to any person, or whoever unlawfully and with intent to avoid payment by himself or another person for a prospective or previously rendered service prevents an electric meter from duly registering the quantity of electricity supplied, or in any way interferes with its proper action or just registration, or, without the consent of such corporation or person, unlawfully and intentionally diverts or suffers to be diverted any electrical current from any wire of such corporation or person, or otherwise unlawfully and intentionally uses or causes to be used, without the consent of such corporation or person, any electricity manufactured or distributed by such corporation, or charged to such person, shall be punished by a fine of not more than one thousand dollars or by imprisonment for not more than one year, or both.

The existence of any of the conditions with reference to meters or attachments described in this section shall be prima facie evidence that a firm, corporation or other business entity, commercial or industrial, to whom such electricity is, at the time, being furnished by or through such meters or attachments has, with intent to defraud, created or caused to be created with reference to such meters or attachments, the condition so existing; provided, however, that nothing in this paragraph shall be construed to limit the introduction of any other competent evidence bearing upon the question of whether or not the defendant was responsible for the acts alleged to have been committed; provided, further, that the prima facie evidence referred to in this paragraph shall not apply to a residential customer; provided, further, that the prima facie evidence referred to in this paragraph shall not apply to any firm, corporation or other business entity, commercial or industrial, so furnished with electricity for less than thirty-one days or until there has been at least one meter reading, whichever first occurs.

Section 127A:

Whoever unlawfully and intentionally injures or destroys, or suffers to be injured or destroyed, any meter, pipe, conduit, wire, line, pole, lamp or other apparatus belonging to a corporation, including municipal corporations which own municipal lighting plants engaged in the manufacture or sale of electricity or gas or to any person, or unlawfully and intentionally prevents an electric or gas meter from duly registering the quantity of electricity or gas supplied, or in any way interferes with its proper action or just registration, or, without the consent of such corporation or person, unlawfully and intentionally diverts or suffers to be diverted any electric current from any wire or gas from any pipe of such corporation or person, or otherwise unlawfully and intentionally uses or causes to be used, without the consent of such corporation or person, any electricity or gas manufactured or distributed by such corporation, or charged to such person shall be liable to such corporation or person for triple the amount of damages sustained thereby or one thousand dollars whichever is greater. Damages shall include the value of the electricity or gas used and the cost of equipment repair and replacement. Any damages assessed under the provisions of this section in excess of the actual damages sustained by the corporation or person manufacturing, distributing or selling such electricity or gas shall be paid to the commonwealth; provided, however, that if a municipal lighting plant brings an action pursuant to this section such damages in excess of the actual damages shall be paid to such municipal lighting plant.

Report suspected Meter Tampering or Diversion of Electric Service to CEL, Customer Service Department at (413) 594-2400.

CHAPTER 1

INTRODUCTION

1.1 PURPOSE "CEL CUSTOMER SERVICE HANDBOOK"

The "CEL Customer Service Handbook" is issued to provide information to Chicopee Electric Light Customers, Electrical Contractors, Architects and Engineers, in order that electrical installations, to be connected to the Department's System may be made in a standard, uniform and proper manner. The requirements contained herein are supplementary to the Department's Schedule of Rates and Terms and Conditions filed from time to time with the Department of Telecommunications and Energy.

It is not intended that this booklet give complete coverage for wiring details and other lawful requirements. It has been prepared as a guide and is supplementary to the applicable National, State and Local Electrical Codes, Safety Code, OSHA requirements, and to ordinances passed by authorities having jurisdiction. This issuance of this booklet by the Department shall not be construed as relieving the customer and/or his contractor from the responsibility of installing wiring in accordance with Rules and Regulations published by authorities having jurisdiction, nor shall the Department be deemed thereby to have accepted any responsibility for the condition of the customer's wiring and equipment.

Installing new electric service is a joint project between the customer and CEL. CEL is responsible for bringing power to the site, installing the meter in the socket provided by the customer, and energizing the service. The customer is responsible for the following:

1. Obtaining permits and inspections.
2. Providing and maintaining the overhead path or underground trench or conduit for the electric wires.
3. Installing the equipment at the service entrance.
4. Paying all necessary services charges associated with the new / upgraded service.

1.2 RESIDENTIAL SERVICE

Residential service is defined as service to a single-family residence or a multi-family residence such as an apartment or condominium.

Voltage for residential services is typically 120/240 volts, except for special situations. Current ratings (ampacities) available for single-family residences are listed below.

Residential service ampacities:

<u>Current Ratings</u>	<u>Typical Use</u>	<u>Comment</u>
Less than 200 amps 200 amps	Small Homes Medium Homes	The Most Common Service

400 amps
Over 400 amps

Large Homes
Very Large Homes

Apartments or Condominiums

1.3 TEMPORARY SERVICE

Temporary service is defined as electric service to a site for less than one year. The most common use of temporary service is to deliver power during the construction phase of a project. When the project is complete, the temporary service is replaced by permanent service. Temporary services are usually 120/240 volts, single-phase, 100 or 200 amperes.

1.4 BUSINESS SERVICE

Business service is defined as electric service to a commercial or industrial site.

1.4.1 Primary Voltage Service

Business services are typically below 600 volts, delivered from the secondary side of CEL's distribution transformers.

Primary service (13.8 kV) is available to qualified customers, provided the service will not, in CEL's opinion, adversely affect service to other customers or CEL's distribution system, and will be distributed by the customer in a safe and reliable manner.

Customers receiving service at primary voltage may own poles, conductors, cables, transformers, and protective devices. This equipment is subject to approval by CEL. To assure timely restoration of service in case of failure, this customer-owned equipment should be of the same type or specification as equipment used by CEL. Primary voltage service is metered using current transformers, voltage transformers, and transformer-rated meters.

Any customer considering primary voltage service must consult with CEL before construction begins to address the location of the point of delivery, primary metering equipment, disconnect devices to separate power company and customer distribution systems, ferroresonance, system protection, and grounding.

CHAPTER 2

OVERHEAD SERVICES

The cost for overhead service depends on the extent of special engineering required. The least complicated and costly situation is when a transformer is on a pole on, or near the property. If this is the case, engineering may not be required. The customer's electrician simply installs the service entrance equipment, has it inspected, and calls the utility to have service connected. The customer is responsible for providing, installing, and maintaining all equipment from the point of delivery except for the meter.

CEL is responsible for providing and installing the meter, completing the connections between the meter and the service conductors, and making the final connections at the point of delivery. If CTs are being used, the utility also provides the CTs and makes the connections to them and to the meter.

2.1 TYPICAL OVERHEAD SERVICE

1. **Service Lines** are the overhead wires that run from a pole to your house and installed and maintained by CEL.
2. **Service Hook** attaches the service line to the house. CEL supplies the hook and customer's electrician installs and maintains it.
3. **Weather Head** attached to the service cable, this prevents water damage to the wiring. This is installed and maintained by the customer's Electrician.
4. **Service Cable** runs from the weather head to the meter box and from the panel box, inside the house. The service cable is installed and maintained by the customer's electrician.
5. **Meter Socket** is installed and maintained by the customer's electrician.
6. **Meter** is installed and maintained by CEL. (Refer to Figure 2-1, Page 12)

Wiring inside the house is always the customer's responsibility

2.2 TYPICAL OVERHEAD INSTALLATION

The picture in Figure 2-2, Page 13 shows a finished installation of an overhead service. The customer provides everything shown here, except the meter, the overhead service line, and the power pole and pole-mounted equipment.

The following conditions must be met before CEL will energize any Service:

1. Appropriate paperwork is completed.
2. All fees are paid.
3. The customer has installed the service equipment.
4. CEL has received the wiring inspectors approval.

2.3 OVERHEAD LINE CLEARANCES

Figures 2-3 and 2-4, on Page 14 show clearances under overhead lines for the conditions most commonly encountered. The customer does not install the service conductor, but is required to

provide a point of attachment high enough and strong enough, to allow the utility to install the service line and maintain the required clearances.

If the span of the service line exceeds 125 feet, a service pole may be required to relieve the tension on the service hook or mast (Refer to Chapter 5, Page 73 for CEL SERVICE FEE information)

Avoid a route for the service line that passes over a driveway. Lines that cross driveways can be struck by tall trucks and other vehicles, causing damage to the service equipment and to the building. Avoid a route that will require an aerial trespass through property owned by others.

If the service line will pass through trees, the customer must prune or remove the trees to provide a clear path for the line. CEL is responsible for regular tree pruning to keep the path clear. If the service line will pass over brush, the customer must clear a path for CEL's installation service personnel.

Refer to Figure 2-5, Page 15 for the horizontal clearances from a swimming pool

2.4 HORIZONTAL CLEARANCES FROM ROADWAY, RAILWAY AND HYDRANTS

Figures 2-6a, 2-6b and 2-6c on Page 16 show horizontal clearances from Roadways, Railways and Hydrants. For other situations and for additional details, see the NATIONAL ELECTRICAL SAFETY CODE, or contact the City of Chicopee, electrical inspector.

2.5 CHECK LIST FOR INSTALLING OVERHEAD SERVICE

The customer is responsible for providing, installing, and maintaining all equipment beyond the point of delivery, except for the meter. CEL is responsible for providing and installing the meter, completing the connections at the weather head, and making the final connections at the point of delivery. If CTs are being used, the utility also provides the CTs and makes the connections between them and the meter.

To obtain new overhead service, the customer / electrician shall:

- a. Check if local regulations permit the installation of an overhead service.
- b. Contact CEL to open an account and complete an "Application for Service". Forms can be obtained at the CEL Customer Service Department. (Refer to CEL's Terms and Conditions)
- c. Make arrangements for a service deposit, if required. (Refer to CEL Terms and Conditions)
- d. Obtain an electrical work permit from the Building Dept. located at City Hall.
- e. Fill out and return a "Service and Meter Location" form to CEL Customer Service Department. (Refer to Chapter 5, Page 78)
- f. Install the service equipment.
- g. Receive approval from the City of Chicopee wiring inspector for electric service before any service can be connected to any new, or newly wired building, structure or residence.
- h. Pay all fees for any additional equipment that may be needed to provide electric services to the property. (Refer to Chapter 5, Page 73 For CEL Service Fee Information)

Upon all above requirements being met, CEL will:

1. Install the meter in the meter socket, and
2. Install the service from the pole to the weather head and make all necessary connections at the pole and building

2.6 SERVICE MAST, METER

The pictures in Figure 2-7a, Page 17 and Figure 2-7b, Page 18 show details of a service mast, with the meter on the surface of the building. The service could be wired to an exterior meter as shown. The customer installs everything in the picture, except the meter.

The following conditions must be met before CEL will energize an overhead service with a mast:

1. Appropriate paperwork, including the Application for Service and Meter and Service Locate Form, must be completed.
2. "Waiver For Vertical Mast" form is completed. A sample copy of this form can be found on Page 19. Form can be obtained at the Customer Service Dept.
3. All fees are paid.
4. The customer has installed the service equipment.
5. CEL has received the approval of the wiring inspector.

2.7 TEMPORARY OVERHEAD SERVICE, METER POST

Figure 2-8 on Page 20 shows a finished installation for a temporary service using a meter post. The customer provides everything shown, except the meter and the overhead service line.

The following conditions must be met before CEL will energize the temporary service.

1. Appropriate paperwork must be completed.
2. All fees are paid*
3. Location of temporary service pole to be specified by CEL such that the service drop can later be transferred to the permanent location and:

Note: The service drop span not to exceed 125 feet measured from the utility pole to the meter post. If the span of the service line exceeds 125 feet a service pole may be required (Refer to Chapter 5, Page 73 for CEL Service Fee Information) to relieve the tension on the temporary meter post, and to maintain clearance over the roadway.

4. If timber is used, it shall be structural grade fir or pine with cross section not less than nominal 6"X6".
5. The temporary service pole shall be at least 20 feet long. Additional length may be required to provide service drop minimum clearances of 16 feet over the road and driveway and 12 feet over other areas.
6. The temporary service pole shall be set a minimum of 4 feet in firm ground with well tamped backfill
7. The temporary service pole shall be adequately braced to support at its top, both a man on a ladder and a service drop tension of 600 pounds. A minimum of three 2" X 4" braces, one-in-line with the service drop, and the other two braces at right angles to the brace that is in line with the service drop.
8. There shall be no excavation near the temporary service pole or its braces that might reduce its stability.

9. A weather head shall be installed approximately one foot from top of pole and minimum 16 feet above ground.
10. An approved meter socket shall be installed approximately 5 feet above the existing grade.
11. CEL receives the City of Chicopee wiring inspector's approval.

Notes:

- a) Refer to Chapter #5, Page 73 For CEL Temporary Service Fee Information
- b) If a Three Phase Temporary Service is required contact the CEL Engineering Department.

2.8 OVERHEAD SERVICE, METER POLE

Figure 2-9 on Page 21 shows an overhead service to a meter pole. The customer provides everything in the picture, except the meter and the overhead service line. (Pole can be installed by CEL at a service charge.)

After the customer installs the service equipment, CEL installs the meter in the meter socket, installs the service line and makes all necessary connections between the service line and service entrance cable. (Refer to Chapter #5, Page 73 for CEL Service Fee Information.)

TYPICAL OVERHEAD SERVICE

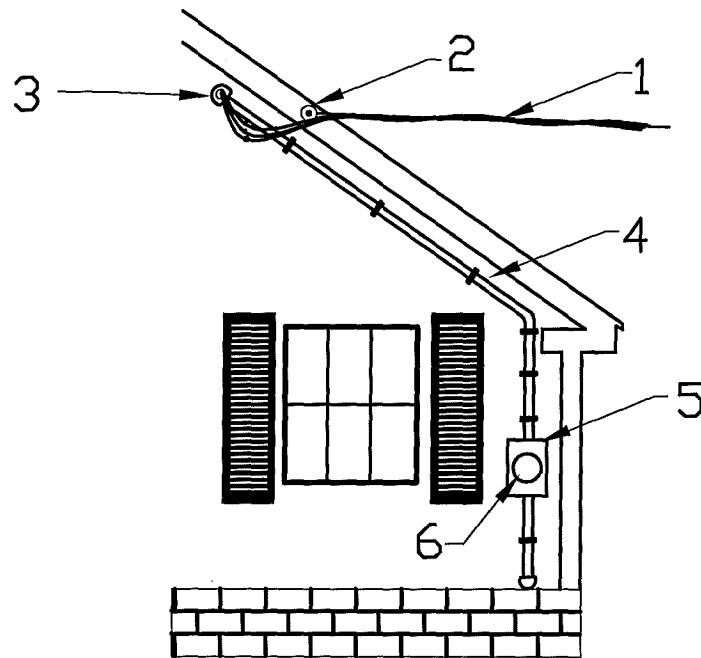

FIGURE 2-1

1. SERVICE LINES
2. SERVICE HOOK
3. WEATHER HEAD
4. SERVICE CABLE
5. METER SOCKET
6. METER

TYPICAL OVERHEAD SERVICE

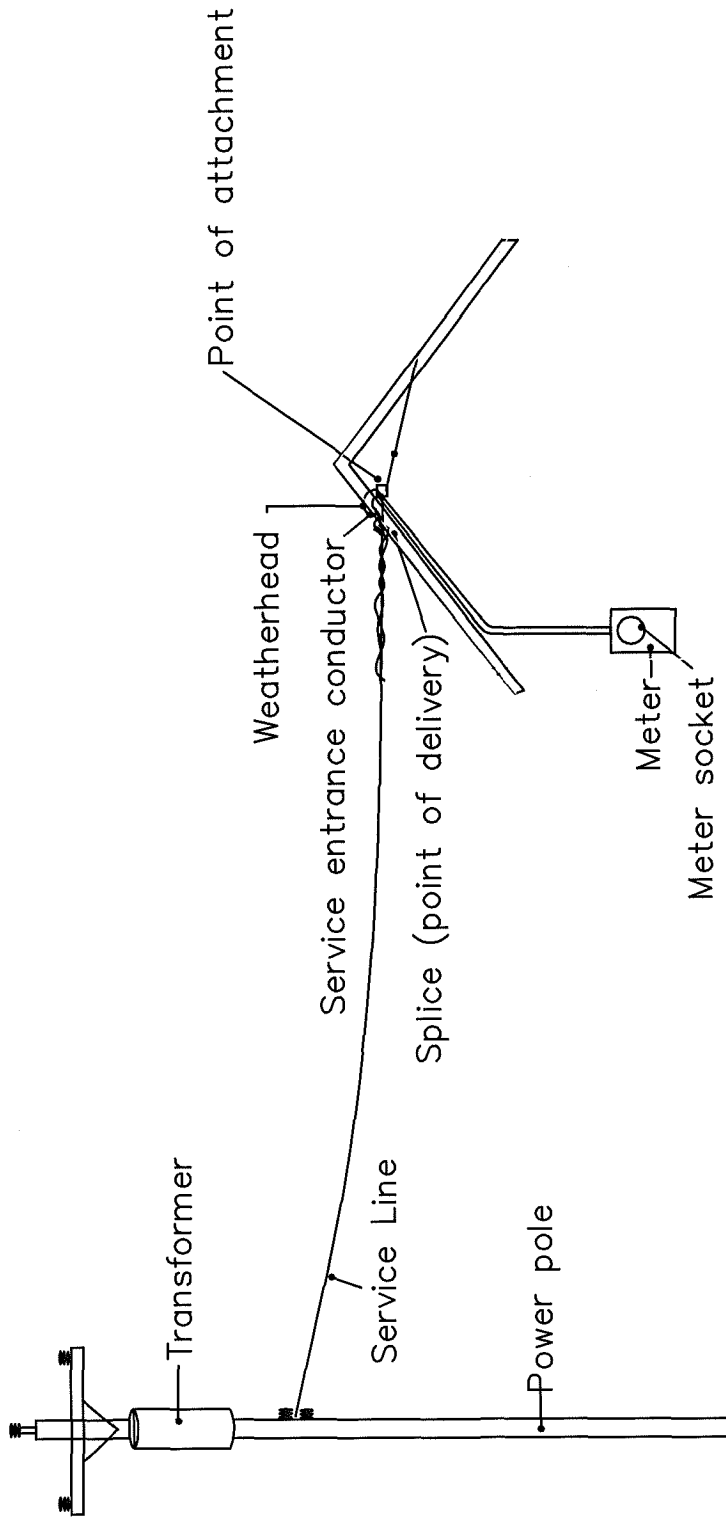
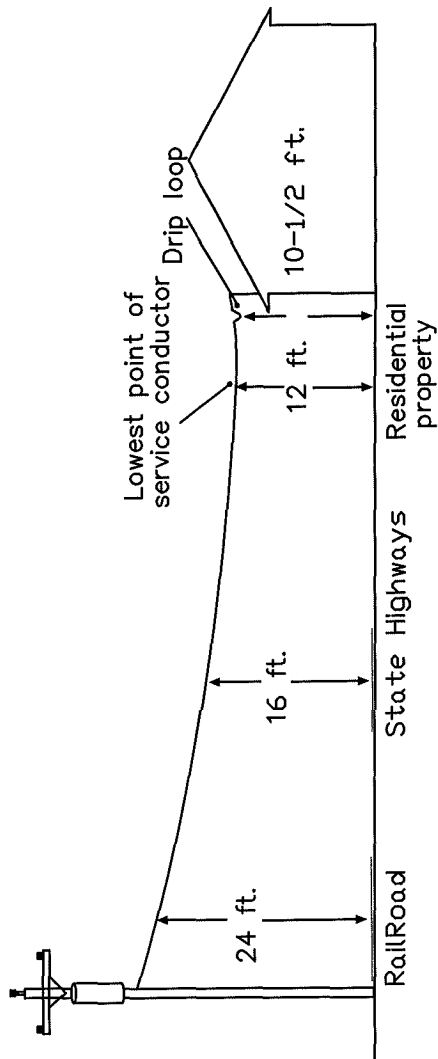
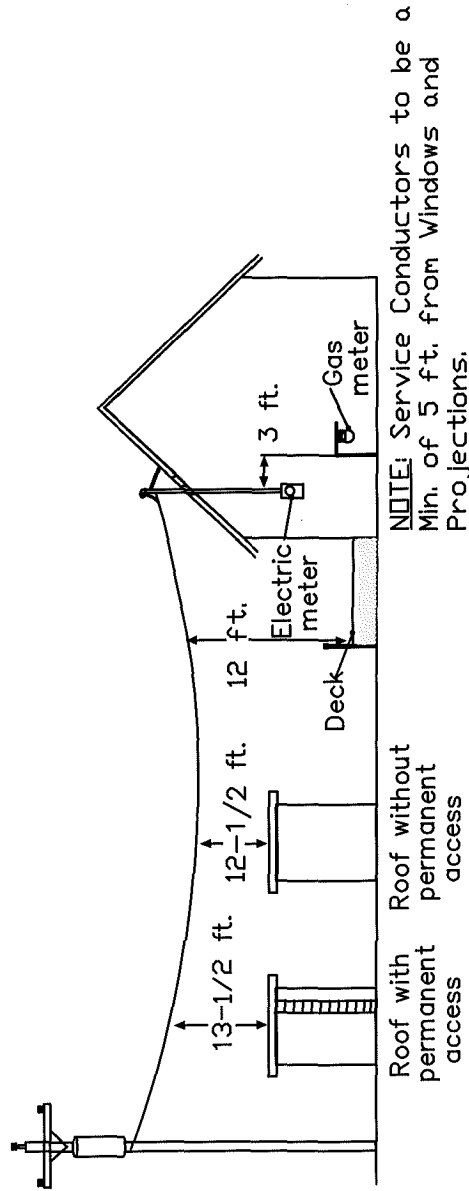

FIGURE 2-2

MINIMUM OVERHEAD LINE CLEARANCES



MINIMUM OVERHEAD LINE CLEARANCE
FIGURE 2-3



NOTE: Service Conductors to be a Min. of 5 ft. from Windows and Projections.

MINIMUM CLEARANCES OVER OTHER STRUCTURES
FIGURE 2-4

CLEARANCES OF WIRES, CONDUCTORS,
OR CABLES OVER OR NEAR SWIMMING
AREAS AND SWIMMING POOLS

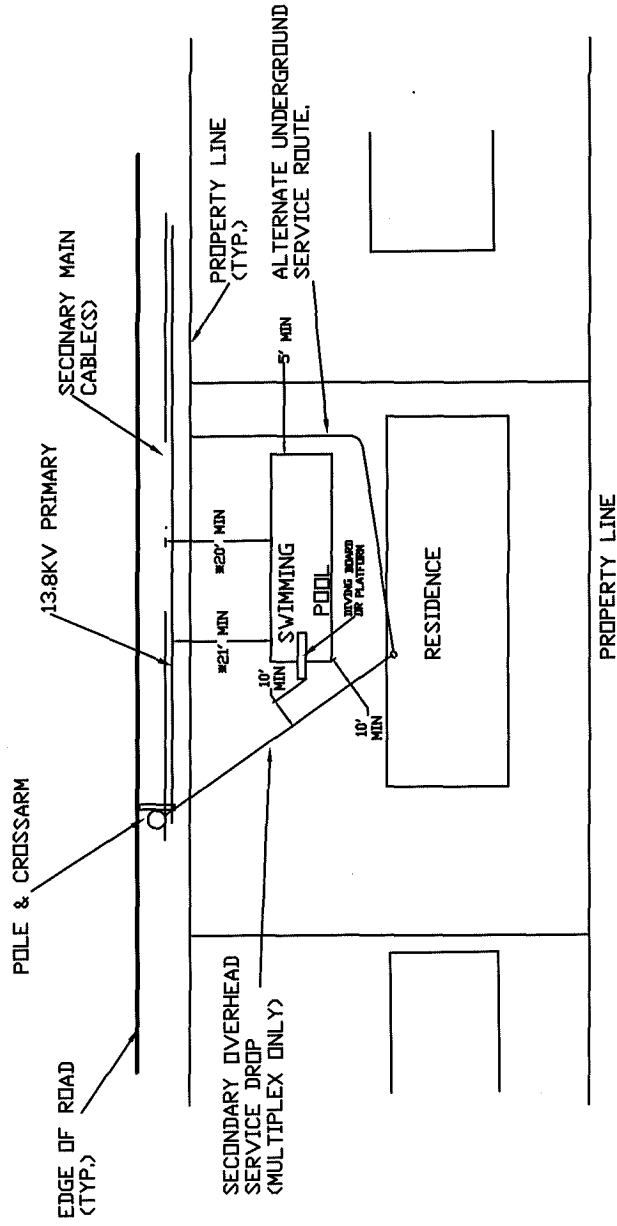
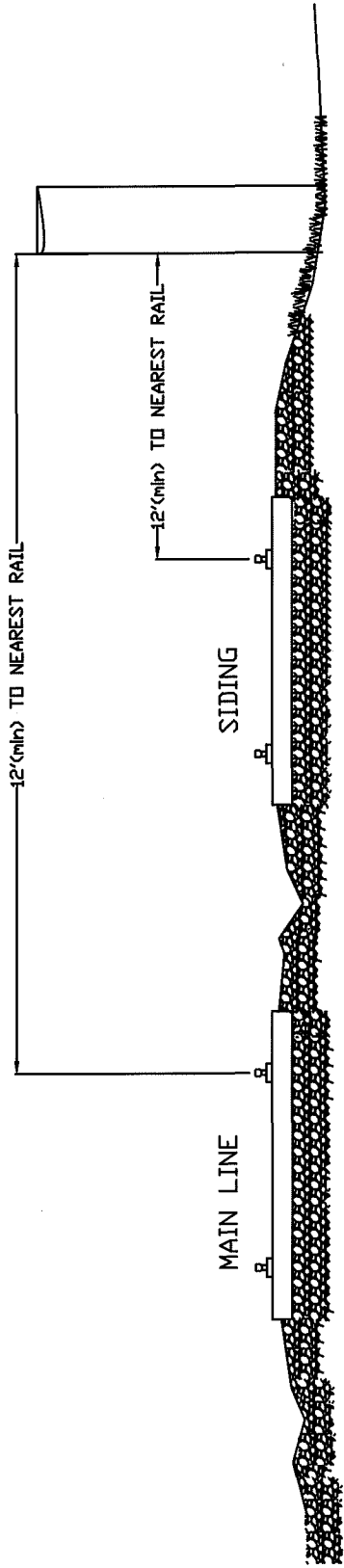
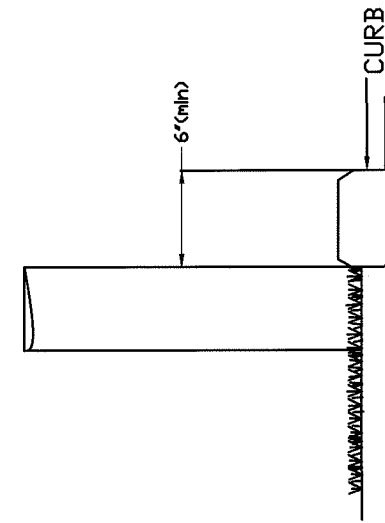

FIGURE 2-5

HORIZONTAL CLEARANCES



HORIZONTAL CLEARANCE FROM A RAILROAD
FIGURE 2-6A



HORIZONTAL CLEARANCE FROM ROAD SIDE
FIGURE 2-6B

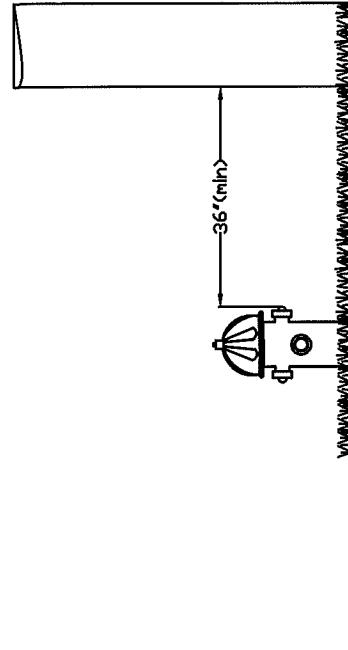

HORIZONTAL CLEARANCE FROM A HYDRANT
FIGURE 2-6C

OVERHEAD INSTALLATION

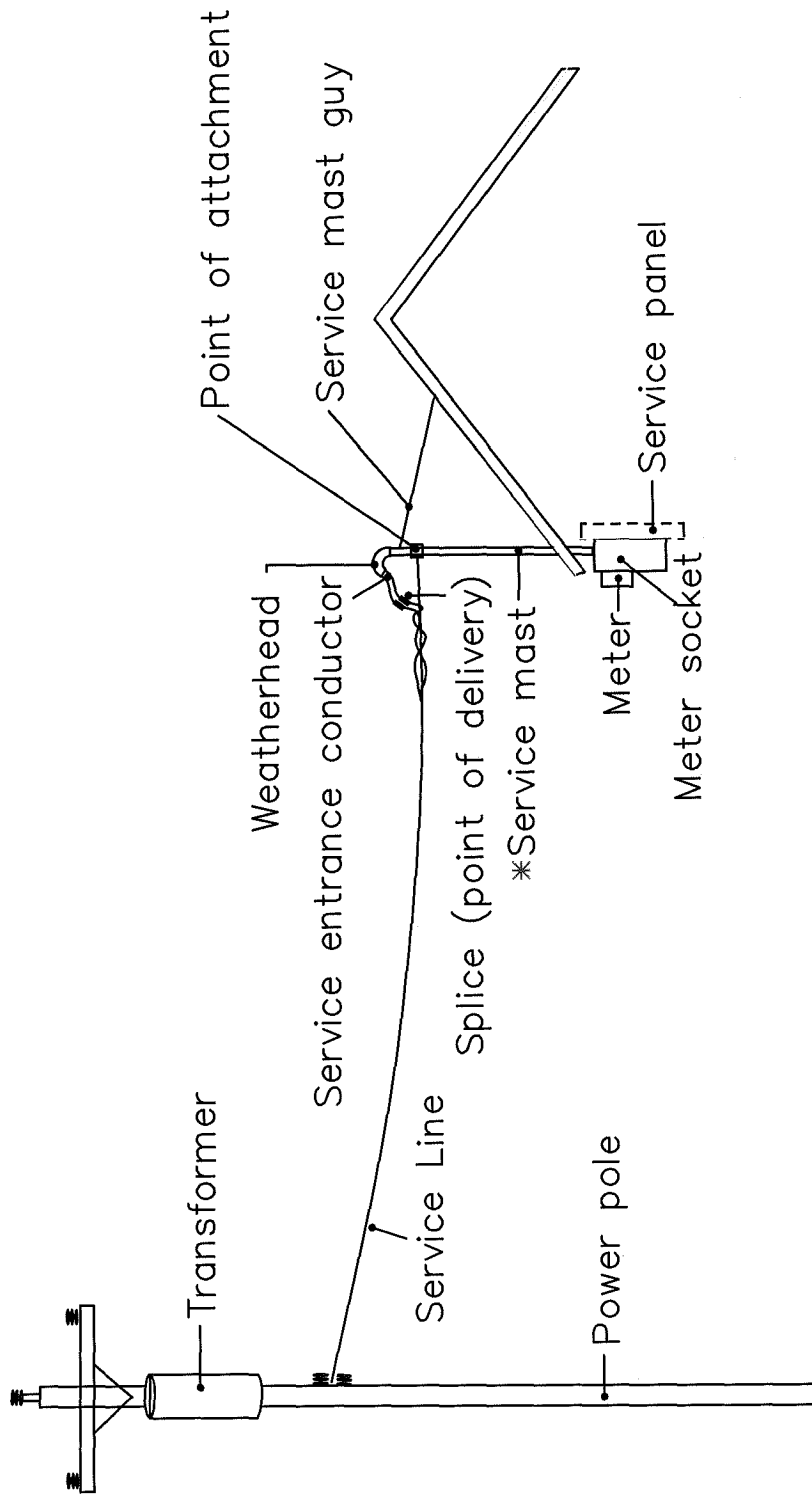

FIGURE 2-7A

SERVICE MAST METER

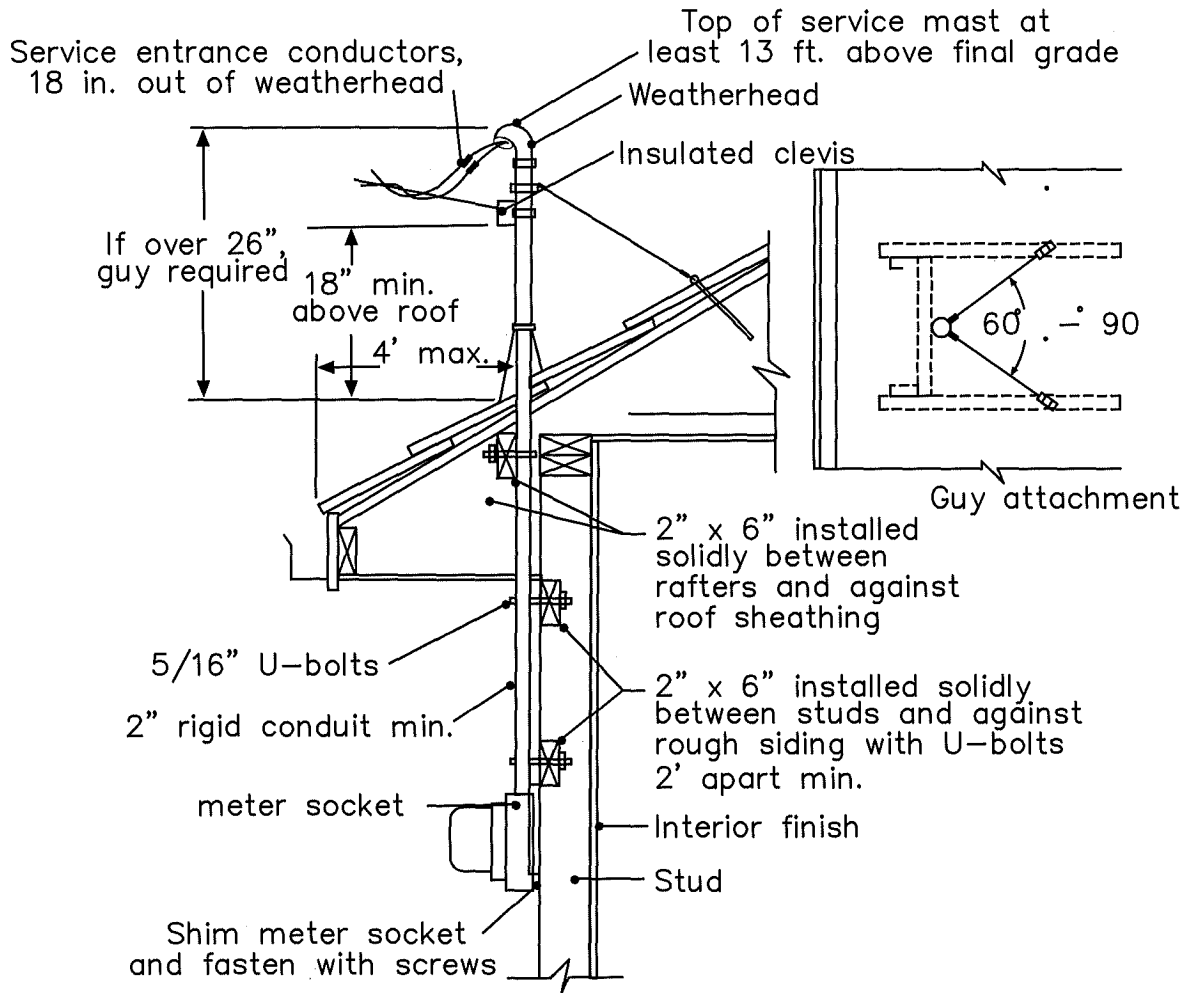

FIGURE 2-7b

WAIVER FOR VERTICAL MAST



CHICOPEE ELECTRIC LIGHT

CHICOPEE ELECTRIC LIGHT

725 Front Street

P.O. Box 405

Chicopee, MA 01020

Name: _____

Owner of the Property at: _____

acknowledge the Chicopee Electric Light policy not to provide electric service to a building by means of attaching service conductors to a roof penetrating or side mounted vertical mast.

If CEL will waive its' policy and supply electric service through means of the existing mast, I affirm that the City of Chicopee will not be responsible for any damage, either personal or property, which occurs as the result of such mast having been used or installed.

Signed: _____

Date: _____

TEMPORARY SERVICE

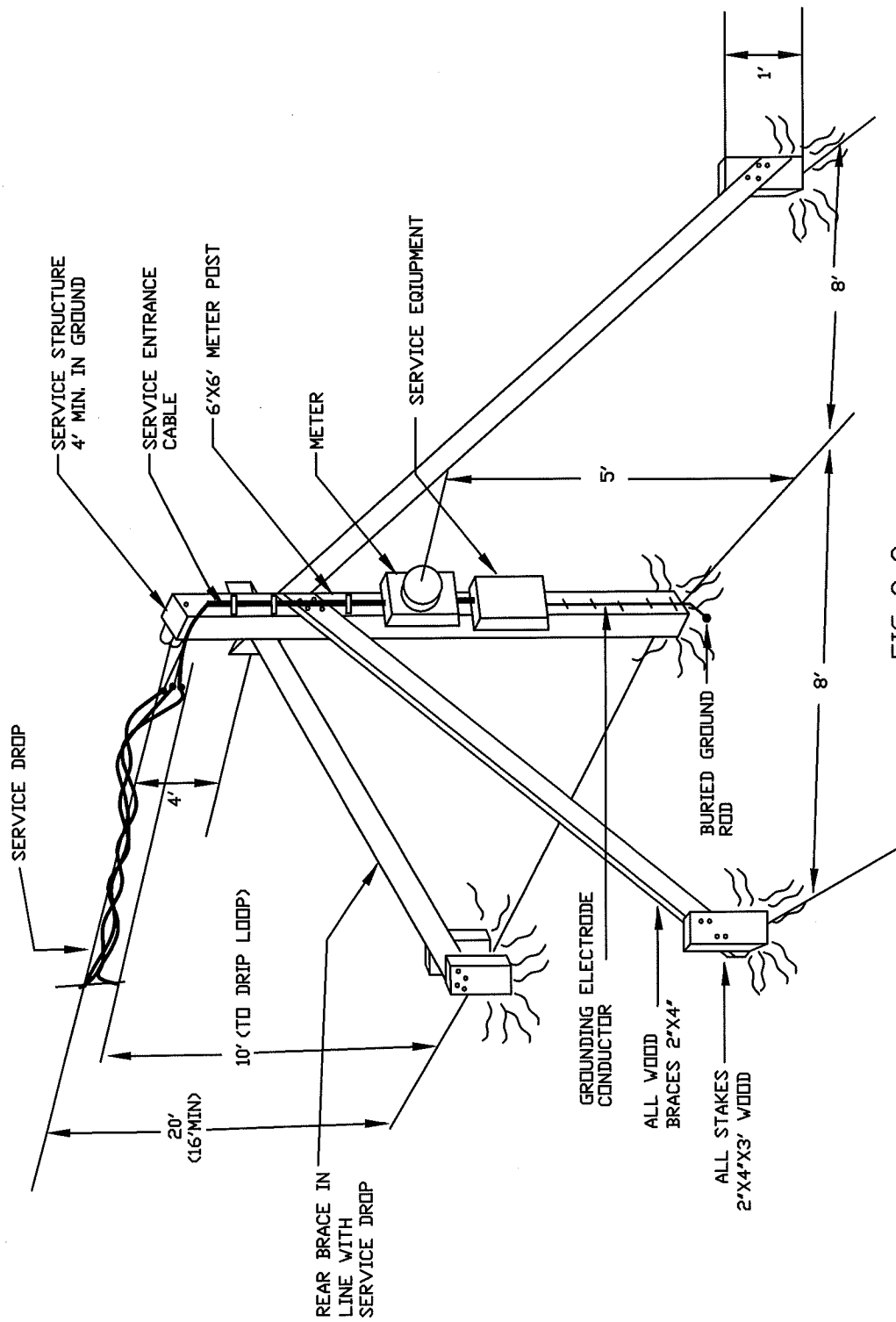

FIG 2-8

OVERHEAD SERVICE METER POLE

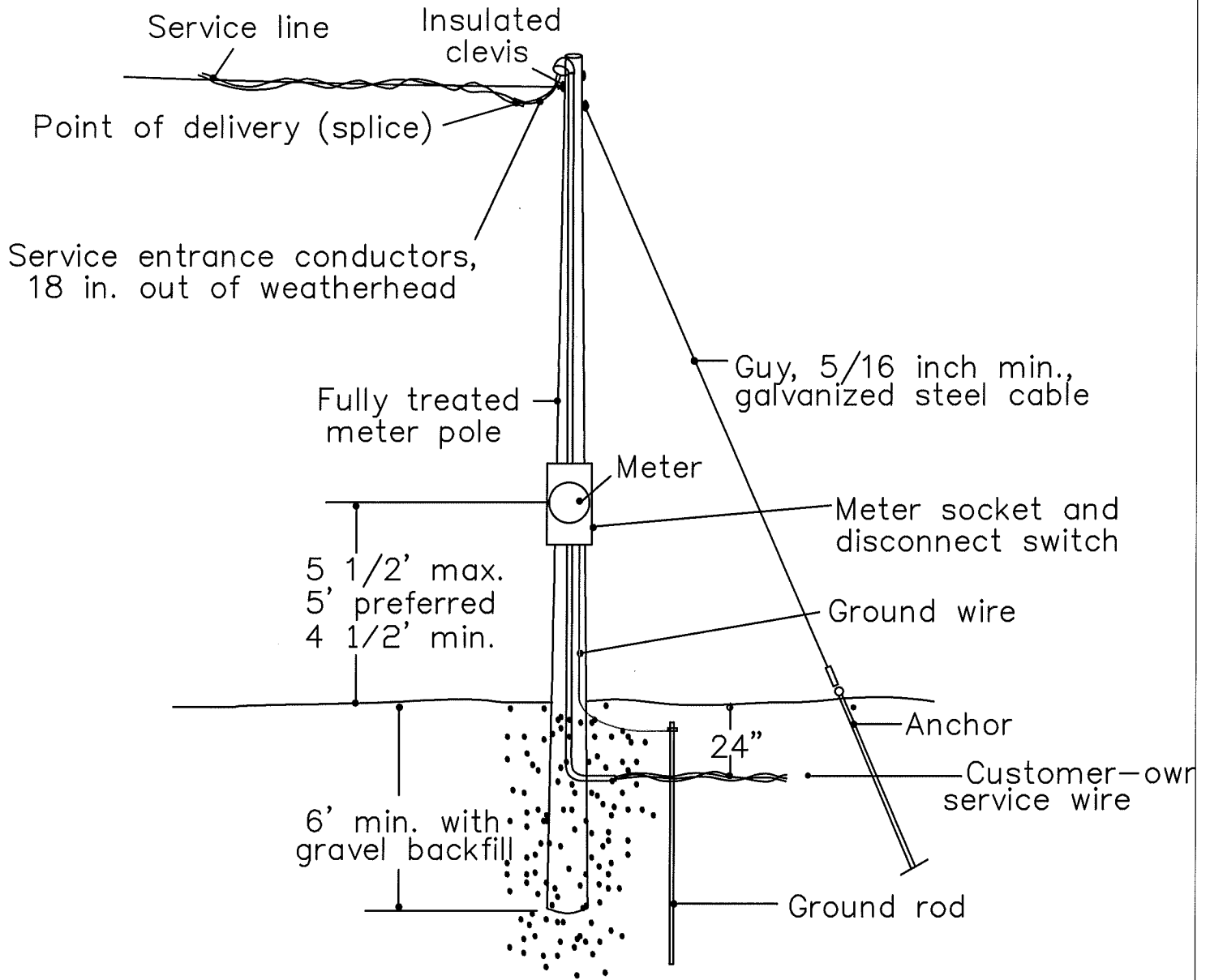

FIGURE 2-9

CHAPTER 3

UNDERGROUND SERVICES

The cost for underground service depends on the extent of special engineering required. The least complicated and costly situation is if a CEL pole, stubout, or handhole is already near the property. If this is the case, engineering may not be required. The customer's electrician simply installs the conduit and service entrance equipment, has it inspected, and calls CEL to have the service connected.

The customer is responsible for providing, installing, and maintaining all equipment from the point of delivery except for the meter.

CEL is responsible for providing and installing the meter, completing the connections at the point of delivery between the meter and the service conductor, and making the final connections at the point of delivery. For new padmount Transformers Installations, the electrical contractor connects and hand tightens the secondary conductors to the transformer, leaving CEL to make the final torqued connections. If a new Electric Service is to be installed to an existing padmount Transformer, the electrical contractor must coordinate with CEL's Engineering Dept. to schedule a time to take the transformer out of service. The electrical contractor can make no connections to the transformer until this time has been scheduled. On CT rated services, CEL also provides the CT's (to be installed by the electrical contractor) and makes the connections to them and to the meter.

3.1 CHECK LIST FOR INSTALLING UNDERGROUND SERVICE

To obtain a new underground service, the customer / electrician shall:

1. Contact CEL to request the service and discuss the project to determine the point of delivery and where the service line will originate.
2. If requested, provide CEL with:
 - a) Site drawings or digital copy (if available)
 - b) Load information
 - c) An easement for permanent equipment owned by CEL and installed on the customer's property. (Only required if customers other than the property owner are supplied electric service from this equipment.)
3. Obtain an electrical work permit from the City of Chicopee's Building Dept.
4. Fill out and return a "Service & Meter Location" form to CEL Customer Service Dept. (Refer to Chapter 5, Page 78)
5. Call the "Dig Safe Call Center" to locate any existing underground wires, cables and pipes - this shall be the responsibility of the excavator.
6. Dig a trench from the point of delivery to the meter location.
7. Place the conductors in the trench or conduit - both conductor and conduit to be properly sized per the Mass. Electrical Code (Refer to Pages 23 & 24 for the options available to the customer).
8. Install the service equipment.

9. Label the conductors at the meter location and connect the conductors to the meter socket, if applicable.
10. Complete all appropriate paperwork.
11. Pay all required fees.
12. CEL receives the City of Chicopee Electrical Inspectors approval.

If all the above conditions have been met, CEL will:

1. Connect the conductors at the point of delivery, or makes the final torque connections for pad mounted transformer applications.
2. If CTs are being used, install the CTs and complete the wiring between the CTs, and the meter.
3. Install the meter in the socket.

3.2 LOCATING UNDERGROUND UTILITIES

The customer must call the DIG SAFE CENTER at 1-888-DIG SAFE (1-888-344-7233) and allow three working days (72 Hours) before trenching or excavating for the underground service. One call to the locating service notifies all utilities that locates. In some areas, not all utilities are members of the one-call system. When working in Chicopee, the customer/excavator must contact the City of Chicopee Water Dept. and Department of Public Works. Excavation must not begin until the location of underground wires, cables, and pipes have been marked, or the utilities have informed the customer that they have no facilities in the area. Any digging within 24 inches of location marks must be done by hand.

The color code for marking underground utilities is:

<u>Color</u>	<u>Underground Service</u>
Red	Electric
Yellow	Gas, Oil, Steam
Orange	Telephone, Cable TV
Blue	Water
Purple	Reclaimed Water
Green	Sewer
Pink	Temporary Survey Marks
White	Proposed Excavation

3.3 SECONDARY RESIDENTIAL, AND SMALL BUSINESS SERVICES 400A MAX, SINGLE PHASE 120/240V OR THREE PHASE 208Y/120V

When installing a secondary service the customer has two options:

Option 1: The Customer’s electrician installs the conduit and electrical conductors from the meter location to a CEL pole, handhole, manhole or stub out, leaving adequate slack to allow CEL to connect to the existing utility-owned conductors. The Electrician shall ensure the installation meets all Mass.

Electrical Code, and NESC requirements Under Option 1, the customer shall own the underground service.

Option 2: The Customer's electrician installs 1 or 2 - 4", schedule 40 conduit with pull string from a CEL pole, handhole, manhole, or stub out to the meter and CEL installs the service conductor at a SERVICE CHARGE to be determined by CEL's Engineering Department. Under this Option, CEL retains ownership of the underground service.

The City of Chicopee Electrical Inspector and CEL Engineering Department must approve both options.

3.3.1. TRENCHING

The customer is responsible for the service trench and installing the required conduit or direct-buried conductors. The customer backfills and compacts the trench.

Trenching rules and tips:

- a) Dig trenches in straight lines between takeoff points, to the greatest extent possible.
- b) Any trenching within two feet of power company facilities must be done by hand.
- c) If any conductors or pipes are encountered while digging, leave them covered.
- d) If rock or other extremely difficult digging is involved, contact CEL to discuss the situation
- e) Provide extra width when digging a joint use trench to allow for a minimum of 12 inches of separation between the electric conduit or cables, and the telephone /T.V. Conduit or cables (Refer to Figure 3-2, Page 30).
- f) Keep the spoils pile at least 24 inches away from the edge of trench.
- g) Schedule the trenching so the trench is open for the shortest practical time to avoid creating a public hazard and to minimize the possibility of the trench collapsing due to other construction activity, rain, etc.
- h) Prior to backfilling, the City of Chicopee Electrical Inspector and CEL Engineering Dept. jointly inspect the trench for adequate depth, conduit or cable placement. If corrections are required, a second inspection is required after the changes are completed.
- i) Place 4 inches of clean bedding material at the bottom of the trench. Clean bedding material is defined as sand or clean soil with no solid material larger than 1 inch. Place the cable or conduit on top of this bed. Then cover the cable or conduit with a 6-inch layer of clean bedding material. Compact the bedding material carefully, so the cable will not be damaged.
- j) Install electric caution tape approximately 12" above the conduit or electric conductors.
- k) The remainder of the trench is backfilled using available clean material. Pieces of scrap cable and other construction items must not be buried in the trench. Tamp the soil, leaving a slight mound to allow for settling.
- l) Soil within 36 inches of riser poles, transformer pads, pedestals, and terminal points must be compacted mechanically.
- m) All rock, debris, scrap cable, and other construction items must be removed from the site.
- n) Trench to the nearest CEL pole, handhole, manhole, or transformer.

3.3.2 SINGLE-USE TRENCH

Secondary Residential and Small Business Services
400 Amps, 1 or 3 Phase
(Refer To Figure 3-1, Page 29)

3.3.3. JOINT-USE TRENCH

Secondary Residential and Small Business Services
400 A, 1 or 3 Phase

The customer may place telephone, cable TV, or other electronic signal conductors in a trench with electric utility wires, providing the installation meets the requirements of the electric utility and all other parties. (Refer to Figure 3-2, Page 30)

3.3.4 Direct-Burial Conductors

All inspections for the trench, conductor size, and conductor placement in the trench will be by the City of Chicopee Wiring Inspector. The installation of the direct-buried conductors shall be the responsibility of the customer’s electrician.

3.3.5. CONDUIT SIZE

Listed in the chart below are the CEL conduit requirements, if CEL is installing the secondary cables.

<u>Current Rating</u>	<u>Single-Phase, 3 Wire</u>	<u>Three-Phase, 4 Wire</u>
0 to 200 amps	One 4 Inch	One 4 Inch
201 to 400 amps	One 4 Inch	Two 4 Inch

3.3.6 UNDERGROUND CONDUIT

When the Customers Electrician is installing the electric conduit, the following conditions must be met:

1. If the conduit run is long or has many bends, an electric handhole may be required (Size of the handhole to be determined by CEL Engineering Dept. - applies only if CEL is to install the service conductor).
2. Electrical – grade Schedule 40 GRAY PVC conduit shall be utilized. Electrical-grade Schedule 80 GRAY PVC to be installed under roadways, railways, driveways, and on the riser pole.
3. The customer shall seal around the conduit where it enters the service panel, and grout where it enters CEL manholes or vaults, to prevent water and other substances to enter.
4. The customer shall coordinate with CEL Engineering Department on conduit entry location and procedures prior to installation into CEL’s handhole, manhole, or vault.
5. An expansion coupling is required between the meter socket and the finish grade. No bends are allowed in this riser other than the 90 degree elbow bend at the bottom of the riser. This bend must have a radius of 36 inches. The customer shall ensure the conduit is plum and attached securely to the structure.
6. After the City of Chicopee Electrical Inspector and the CEL Engineering Dept. inspects the conduit, the trench can be back filled with proper material (Refer to Figure 3-1 on Page 29 or Figure 3-2, Page 30) and 3” Electric Caution tape to be installed approximately 12” above the electric conduit.

Note: CEL Engineering Dept. only needs to inspect the conduit when CEL is installing the electric conductors

7. The customer's electrician shall brush and clean the conduit and install a 900 lb pull string in the conduit with 6 feet of line extended from each end of the conduit and cap the conduit at both ends to keep it free from dirt and debris. This applies only when CEL is to install the service conductors

3.3.7 UNDERGROUND SERVICE METER

Figure 3-3, Page 31 shows a finished underground installation with the meter on the surface of a house. The customer is responsible for everything shown here, except the meter. The source for the service can be a CEL pole, handhole, manhole, or pad mount transformer (Off to the left and not shown here). The requirements needed to install the electric conductors from a CEL pole, handhole, manhole, or pad mount transformer are contingent upon service option chosen.

3.3.8 UNDERGROUND SERVICE, METER WITH PEDESTAL

A meter pedestal is a freestanding structure that supports service equipment for an underground service. If a meter pedestal is called for, it is the customer's responsibility to purchase and install it. (Refer to Figure 3-4, Page 32). It shall be installed between the home and normal public access, and within 30 feet of the home. The pedestal usually contains the disconnect switch required by the Mass. Electrical Code. The requirements needed to install the electric conductors from a CEL Pole, handhole, manhole, or pad mounted transformer are contingent upon which service option the customer chooses.

3.3.9 TEMPORARY UNDERGROUND SERVICE, METER POST

Figure 3-5, Page 33 shows a finished installation for temporary service, using a meter post. The service is underground from a CEL pole, handhole, manhole, or pad-mounted transformer; Conductors placed in the trench bring the power to the base of the post. From the post, the service to the building is usually underground, but could be overhead. The customer provides everything shown, except the meter.

3.4 BUSINESS, INDUSTRIAL OR MULTI-FAMILY RESIDENTIAL BUILDING SERVICES, SINGLE PHASE OR THREE PHASE (400 A or greater, 120/240V, 208Y/120V or 480Y/277V)

The customer shall be responsible for installing the primary conduit, secondary conduit, the precast transformer box pad, ground grid and the service conductors in the conduit, from the transformer to the building, as detailed in Figures 3-10 (Page 38) and 3-11 (Page 39). CEL shall be responsible for providing and installing the padmount transformer at the customer's site.

3.4.1 Safety and Work Clearances around Transformers and Padmount Switchgear

Clearances from pad mount transformers to structures are measured from the nearest metal portion of the transformer, to the structure or any overhang. The minimum clearance from a building or any other structure to the rear and sides of the transformer is 3 feet. A minimum clearance of 10 feet of level working space is required at the front of the padmount transformer. Landscaping and other obstructions must not encroach upon these clearances. A path to access the transformer shall be maintained at all times. Refer to Figure 3-6 (Page 34), 3-7 (Page 35) and 3-8 (Page 36) for additional clearance requirements in the area around padmount transformers.

When it is necessary to install padmount switchgear at a site, a minimum of 10' of clearance on all sides shall be maintained.

3.4.2 Guard Posts (Bollards)

It is the customer's responsibility to install and maintain guard posts (bollards) where CEL equipment is exposed to vehicular traffic.

If the post is placed in stable soil, surround it with 6 inches of concrete. If the soil is unstable or sand, surround the post with 12 inches of concrete.

The location of guard posts to be determined by CEL Engineering Dept. If several guard posts are used, locate them no more than 5 feet apart. For extra visibility, paint the posts traffic yellow. (Refer to Figure 3-9, Page 37)

3.4.3 Pad mounted Transformer Installation

On services that require the installation of a padmount transformer, Chicopee Electric Light Shall Be Responsible For The Following:

1. Providing and installing the required utility poles from the street to the new service location. The number and location of poles and applicable services charges to be determined by the CEL Engineering Dept.
2. Providing and installing the required length of underground primary conductors from the new riser pole or manhole to the transformer pad location, at a service charge to be determined by the CEL Engineering Dept.
3. Providing and installing the pad mount transformer at no cost to the customer. Size to be determined after the CEL Engineering Dept. reviews the proposed load information provided by the customer.

The Owner / Electrician Shall Be Responsible For But Not Limited To, The Following Items:

1. Providing and installing the precast concrete pad per CEL Specifications - refer to CEL "Construction standard for a single phase transformer pad installation (Figure 3-10, Page 38), or CEL "construction standards for a three phase transformer pad (Figure 3-11, Page 39) for the transformer box size, ground grid layout and guard post layout (Figure 3-9, Page 37).
2. Coordinate with CEL Meter Dept. concerning meter locations and requirements.
3. Coordinate with CEL Customer Service Dept. concerning the following administrative requirements:
 - a. The Electrical Contractor shall fill out and return a "Service and Location Form". Forms can be obtained at the CEL customer Service Department
 - b. The Owner shall fill out and return a "Commercial / Industrial Application For Service Form" if applicable. Forms can be obtained at the CEL Customer Service Dept.
 - c. The Owner shall coordinate deposit requirements if applicable, for installation.
 - d. CEL must receive the City of Chicopee electrical inspector's approval prior to energizing the service.

3.4.4. Dedicated Pole Mounted Transformer Installation

Chicopee Electric Light shall be responsible for the following:

1. Providing and installing a dedicated single-phase transformer (120/240V) or a three-phase transformer (208Y/120V) at a SERVICE CHARGE to be determined by the CEL Engineering Department
2. Providing and installing the appropriately sized overhead or underground secondary wire from the transformer location to the service attachment point at a SERVICE CHARGE to be determined by the CEL Engineering Dept.

The Owner / Electrical Contractor shall be responsible for, but not limited to the following items:

1. Coordinate with CEL Meter Dept. concerning meter location and requirements.
2. Coordinate with CEL Customer Service Dept. concerning the following requirements:
 - a. The Electrical Contractor shall fill out and return a "Service And Meter Location Form". Forms can be obtained at the CEL Customer Service Dept.
 - b. The Owner shall fill out and return a "Commercial / Industrial Application For Service Form", if applicable. Forms can be obtained at the CEL Customer Service Dept.
 - c. The Owner shall coordinate deposit requirements, if applicable, for installation.
 - d. CEL must receive The City of Chicopee electrical inspector's approval prior to energizing the service.
3. On underground services, providing and installing the conduit from a CEL pole, manhole, or handhole to the meter location - refer to Section 3.3 for options.

3.5 CEL UNDERGROUND DISTRIBUTION STANDARD DRAWINGS

- a. TYPICAL Electrical Handhole Installation: Figure 3-12, Page #40
- b. TYPICAL Underground Conduit Encasement 4 - Bank: Fig. 3-13, Page #41
- c. TYPICAL Manhole Cover and Frame: Figure 3-14, Page #42
- d. TYPICAL Service Manhole (4' x 4' Shown): Figure 3-15, Page #43
- e. TYPICAL Full Size Manhole (5' x10' Shown): Figure 3-16, Page #44

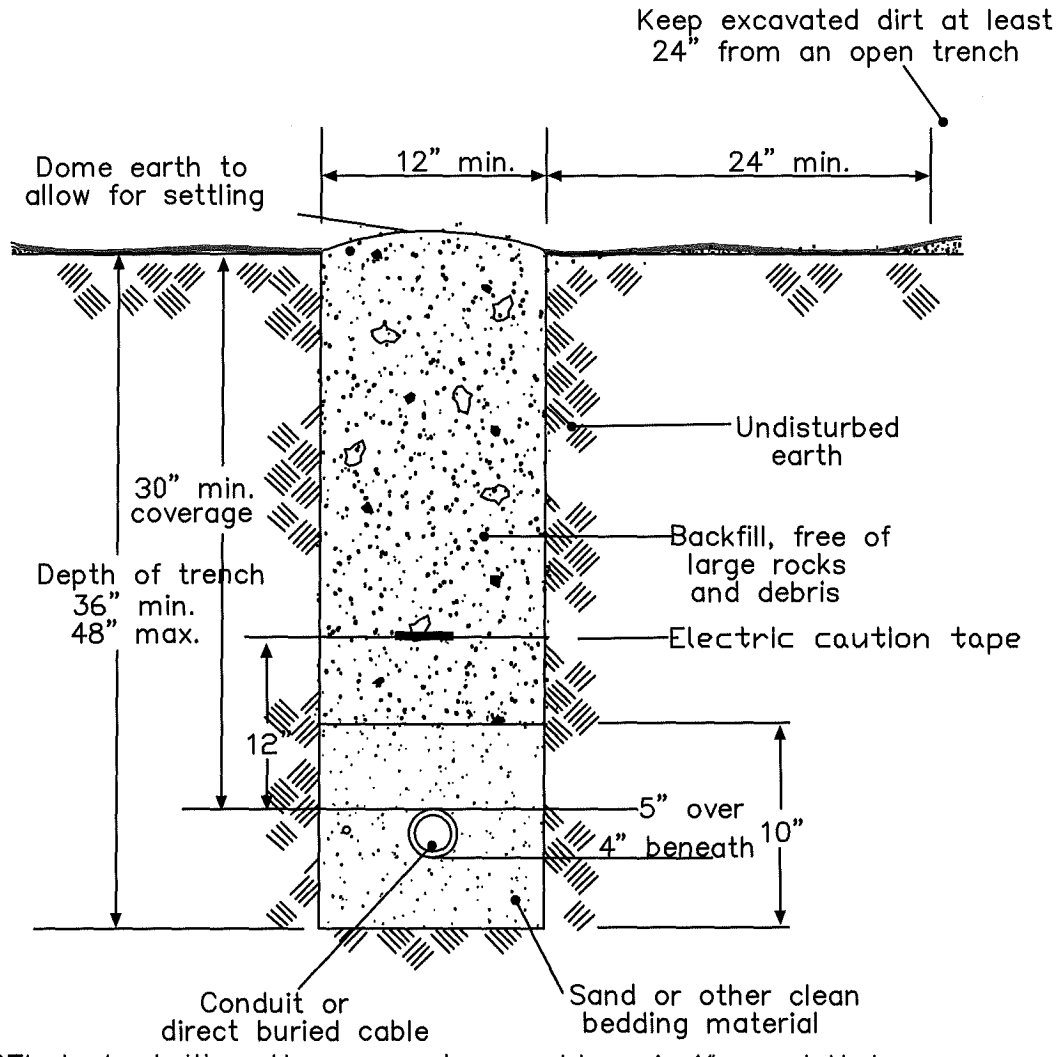

* If CEL is installing the secondary cables. A 4" conduit is required. Option 2 page 23.

SINGLE - USE TRENCH
FIGURE 3-1

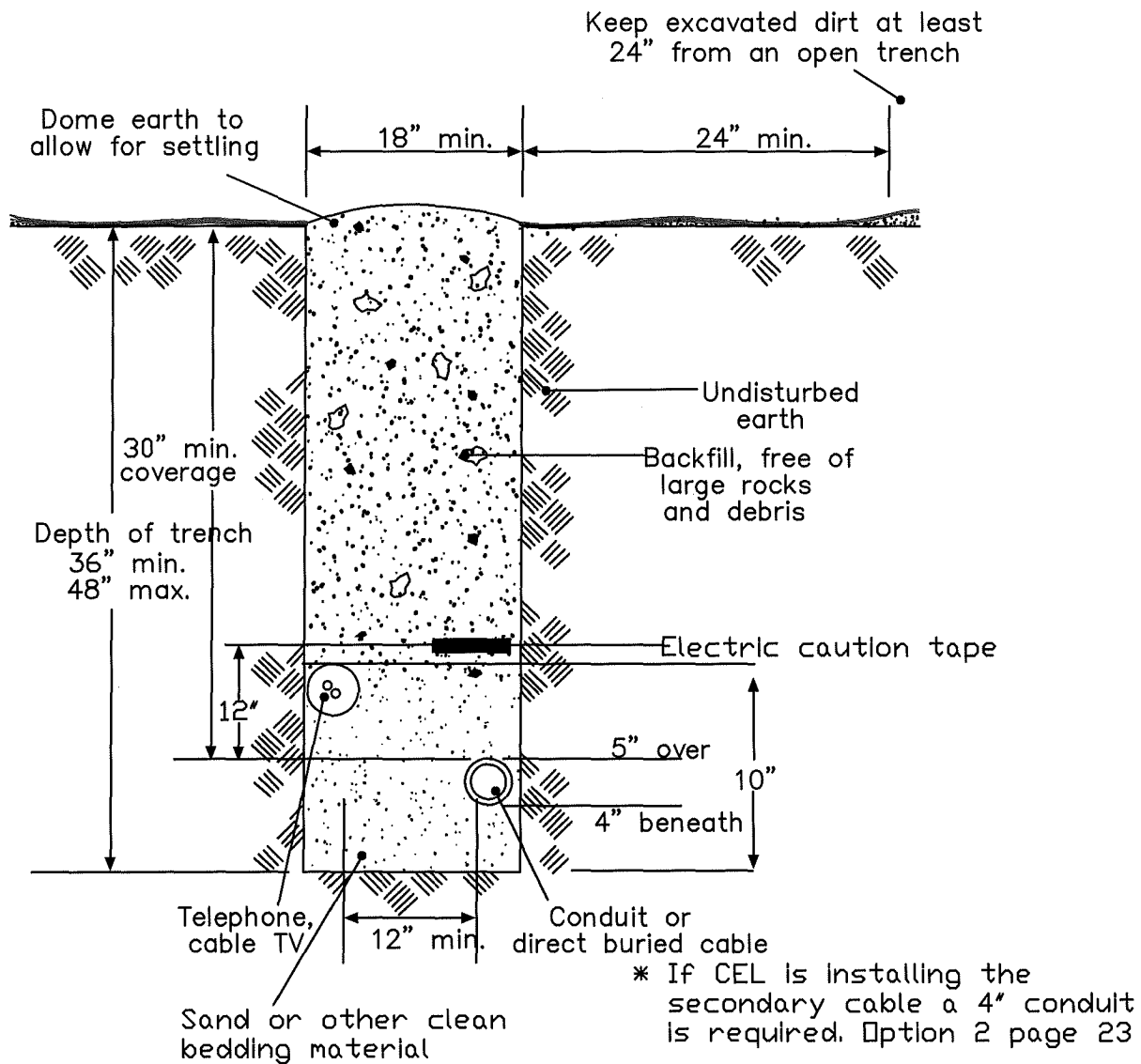

JOINT - USE TRENCH
FIGURE 3-2

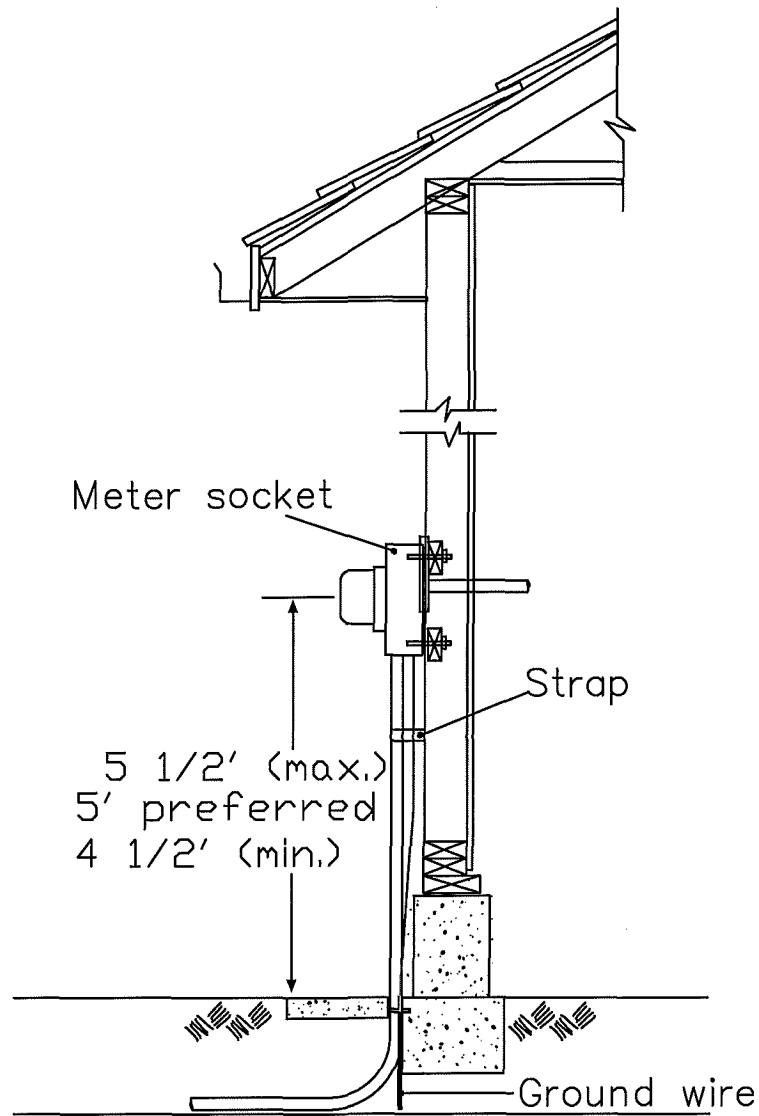

* If CEL is installing the secondary cables, a 4" conduit is required option 2 page 23.

UNDERGROUND SERVICE,
METER

FIGURE 3-3

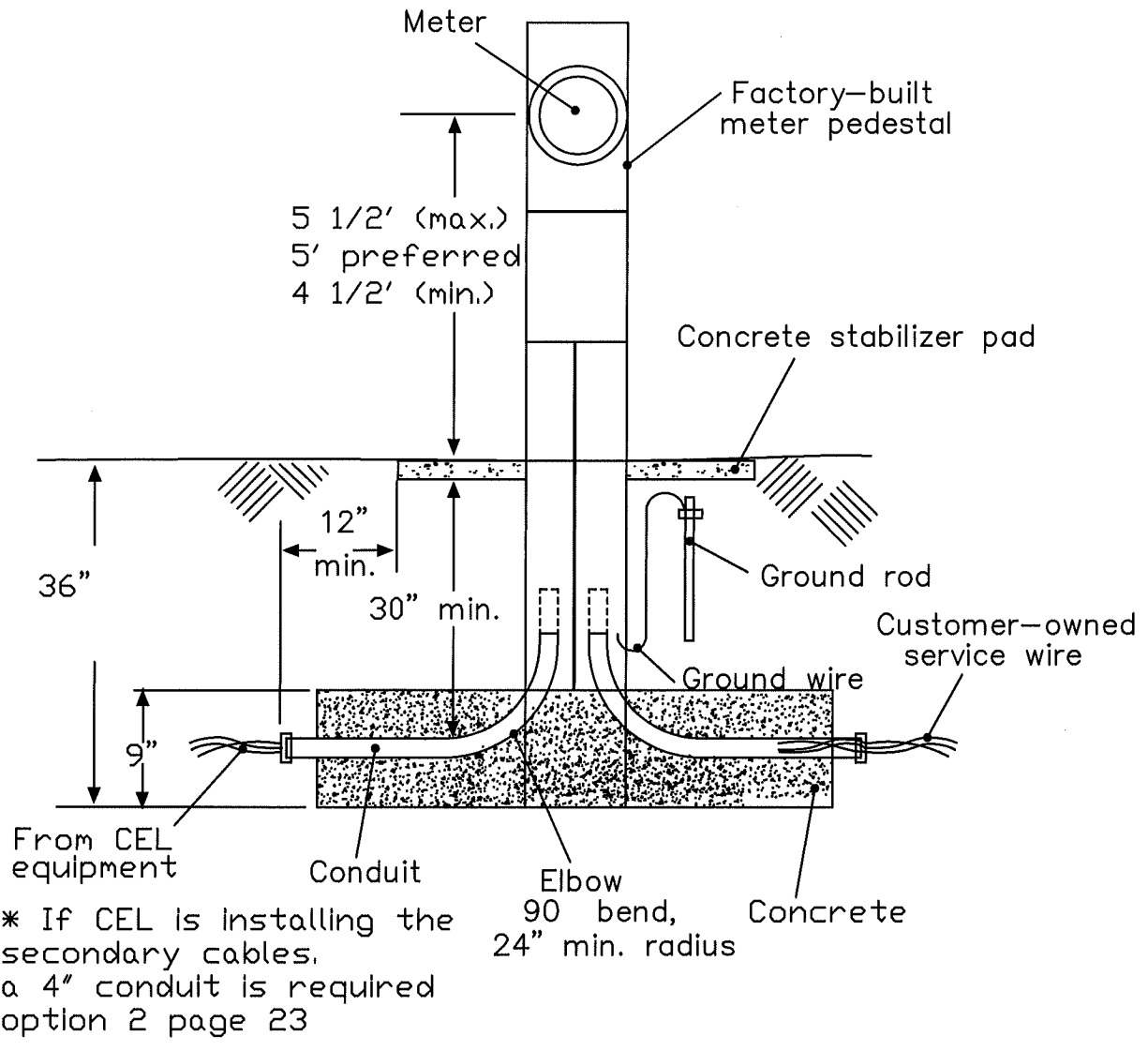

UNDERGROUND SERVICE PEDESTAL METER
 FIGURE 3-4

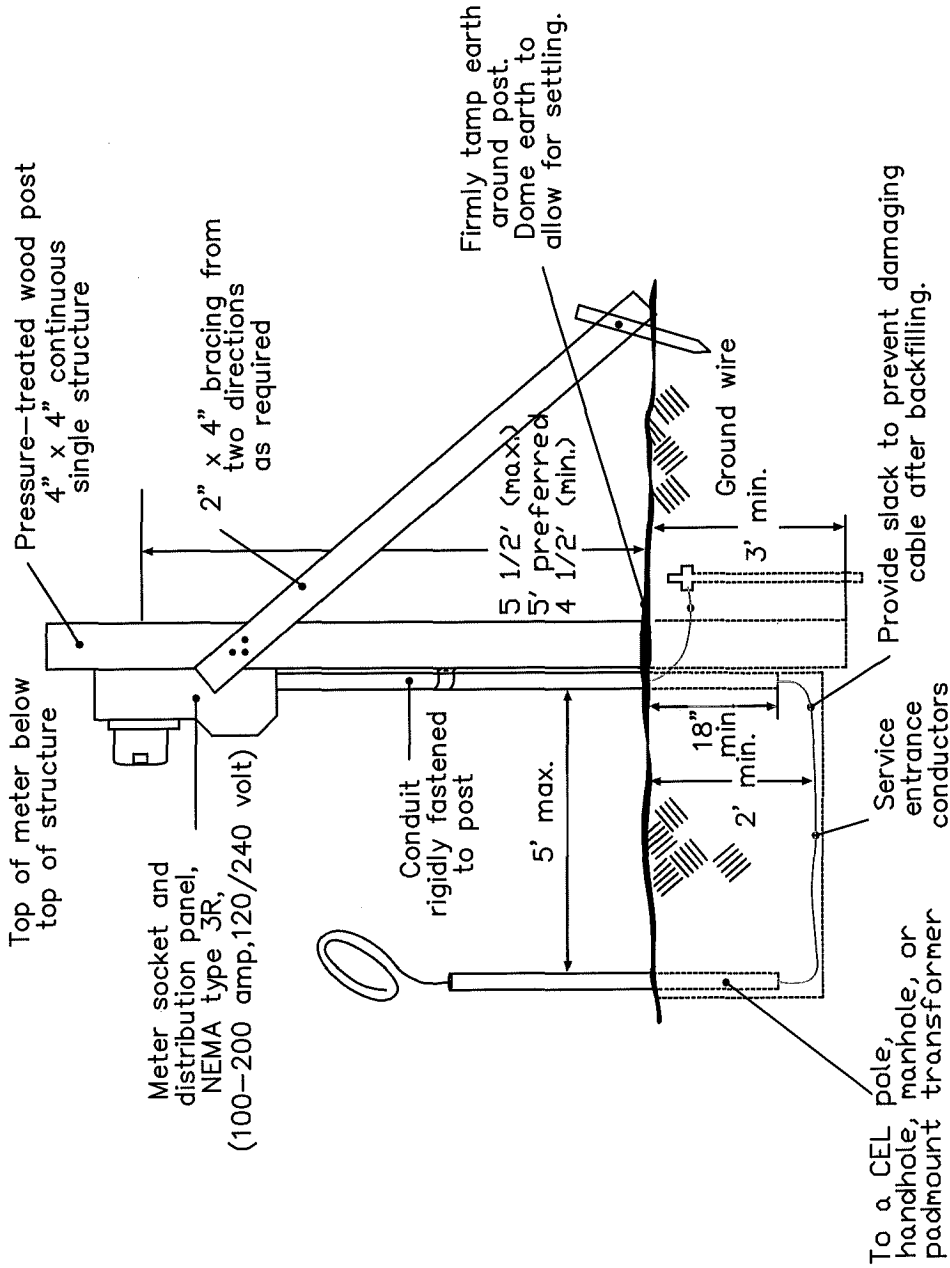

TEMPORARY UNDERGROUND SERVICE METER POST
FIGURE 3-5

NOTE
DO NOT FACE
ACCESS DOORS (FRONT)
TOWARD THE POOL.

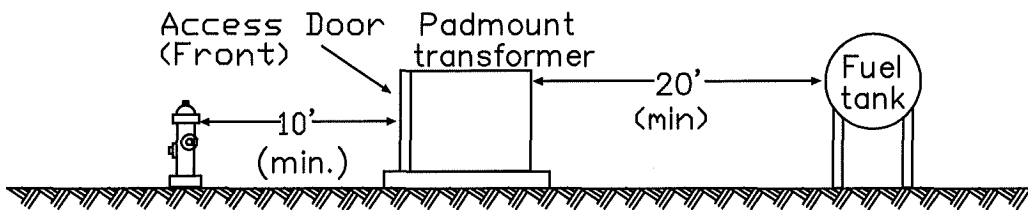
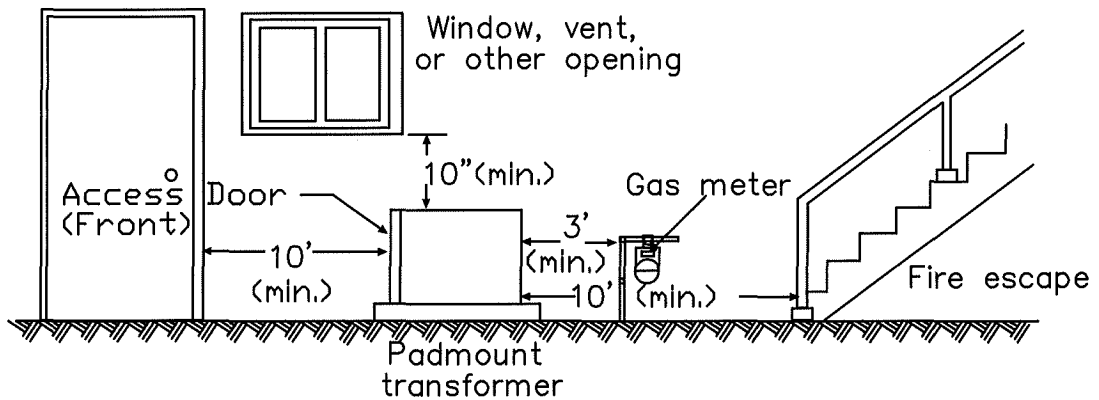
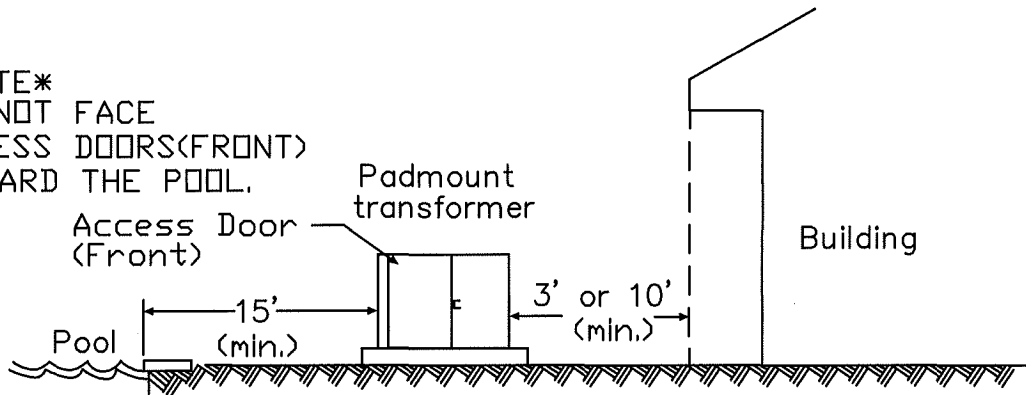

CLEARANCES FROM PAD MOUNTED TRANSFORMER TO STRUCTURES
FIGURE 3-6

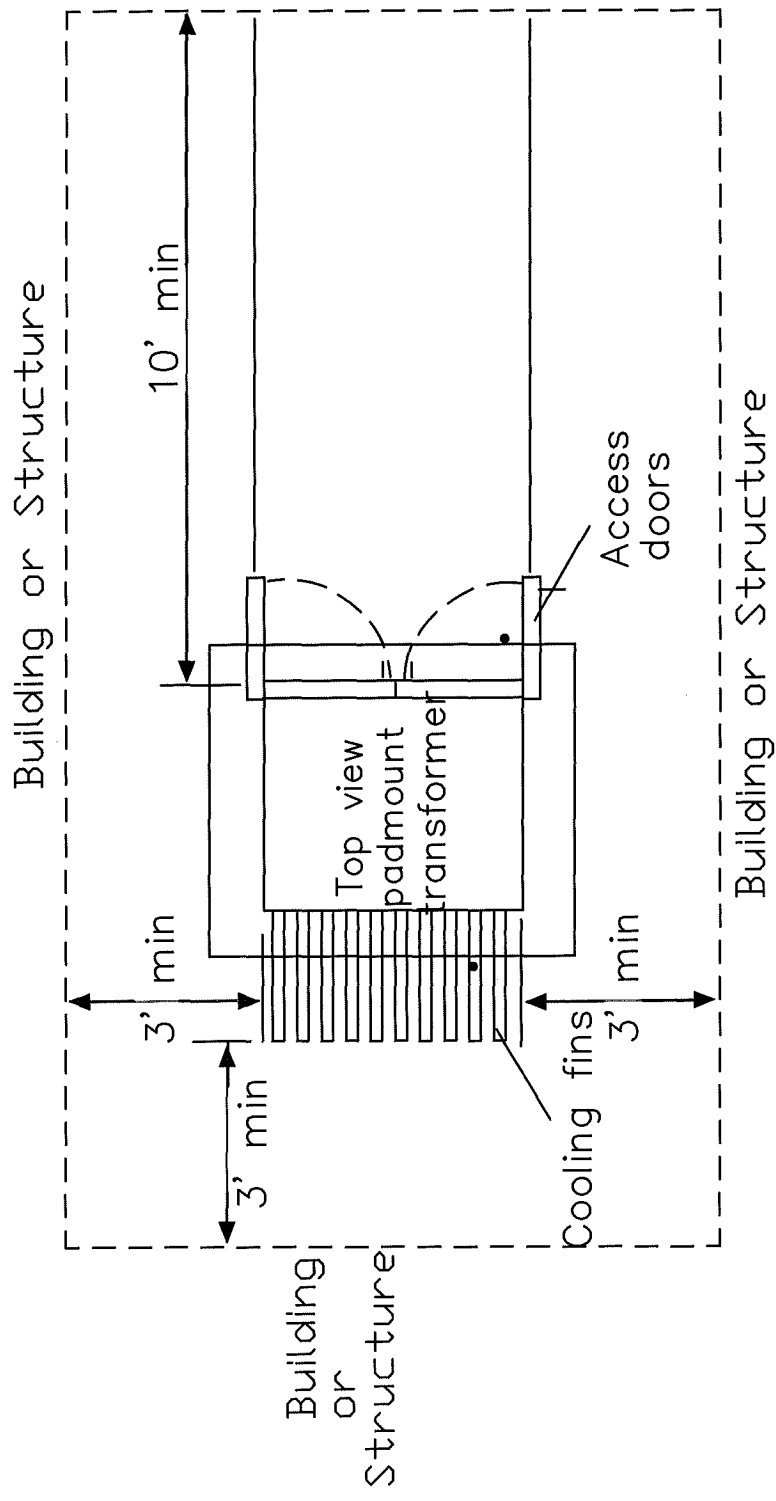

WORK CLEARANCES AROUND TRANSFORMERS
 FIGURE 3-7

CLEARANCE FROM UNDERGROUND UTILITIES

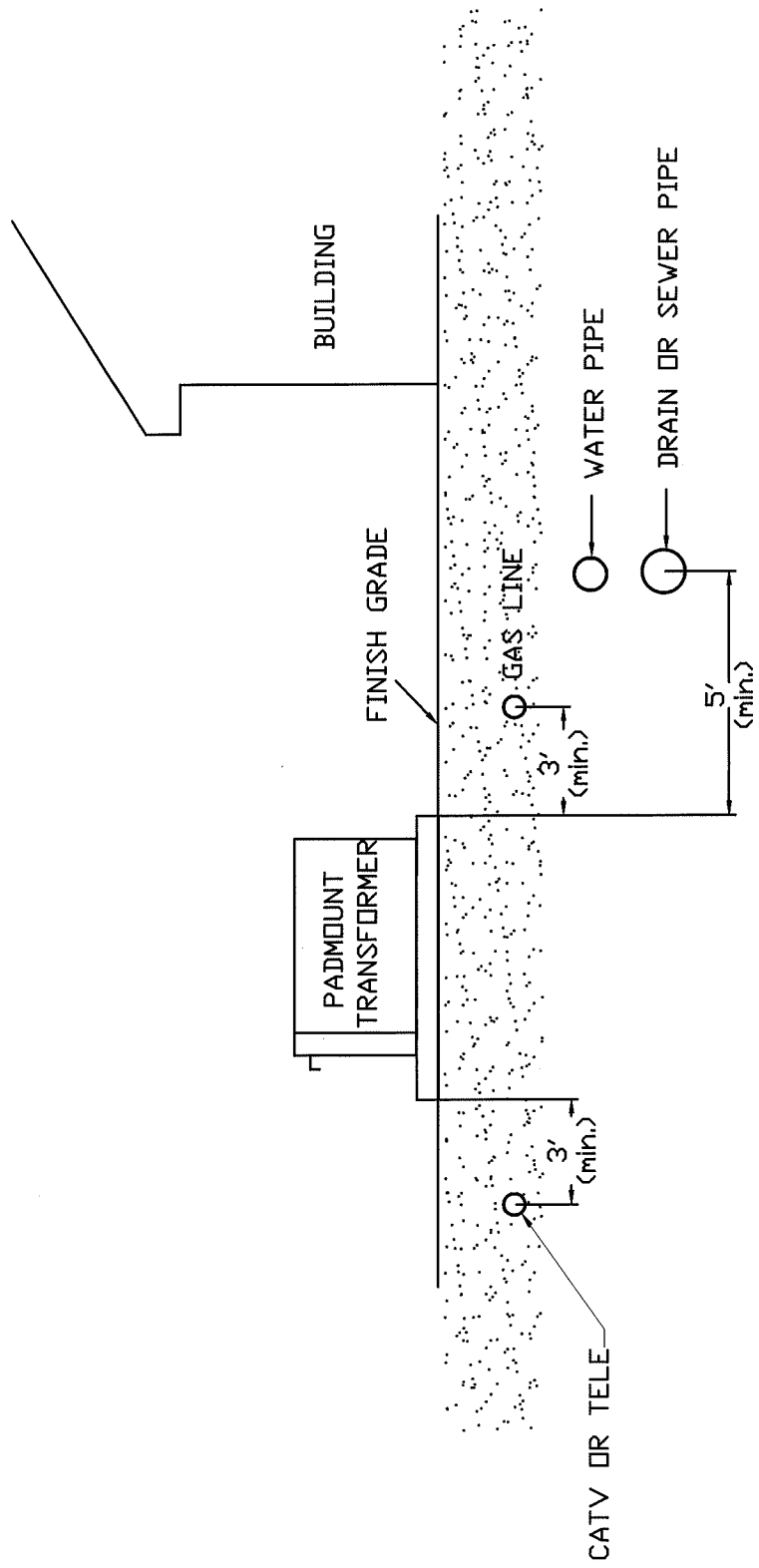
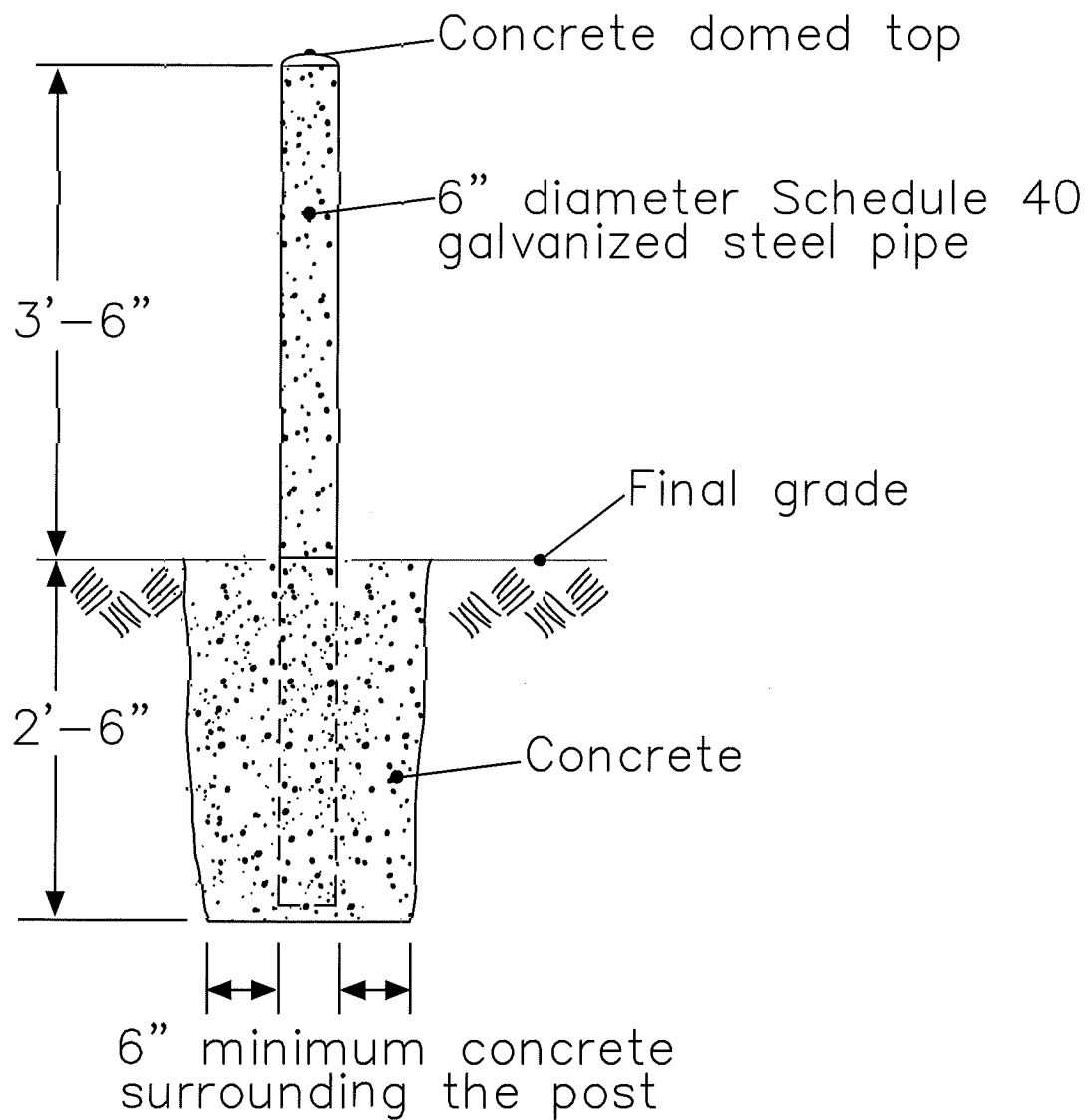

FIGURE 3-8



GUARD POST
FIGURE 3-9

(1) 25 -100 KVA -INSTALL 42" X 48" X 6" PAD, PER ROTONDO MODEL # P-009 WITH A 36" INSIDE DIA. X 38" HIGH PRECAST VAULT MODEL # H020 (OR EQUIVALENT)
 (OR EQUIVALENT)
 (2) INSTALL 48" X 48" X 6" PAD, PER ROTONDO MODEL # P-017 WITH A 36" INSIDE DIA. X 38" HIGH PRECAST VAULT MODEL #H020 (OR EQUIVALENT)

(3) PRIMARY CONDUIT - CONTRACTOR SHALL INSTALL 2-4" & 1-2" (optional for Telecom) SCHEDULE 40, CONCRETE (3000 PSI) ENCASED PVC CONDUIT (3" ENVELOPE AROUND CONDUIT) W/ A MINIMUM OF 36" OF COVER, FROM THE POLE OR MANHOLE TO THE PRIMARY SIDE OF THE PAD.

(4) ALL CONDUIT SHALL BE CLEANED AND BRUSHED.
 (5) A 90° PULL STRING SHALL BE PROVIDED IN EACH CONDUIT.
 (6) 4" (6/8 OR 2") SCH 80 90 DEG. SWEEPS/ELBOWS WITH 36" RADIUS SHALL BE INSTALLED @ THE POLE (C.E.L. ENGINEERING WILL APPROVE LOCATION ON THE POLE). ONE CONDUIT MUST EXTEND 10' UP THE POLE USING SCHEDULE 80 CONDUIT WITH THE OTHER CONDUIT CAPPED/PLUGGED JUST ABOVE GRADE LEVEL. THE CAPPED CONDUIT SHALL ALSO BE CAPPED INSIDE THE TRANSFORMER PAD.
 (7) CONCRETE ENCASEMENT MUST STOP SHORT OF THE POLE - ENCASE THE COUPLING BETWEEN THE CONDUIT & SWEEP/ELBOW.

(8) TRANSFORMER PAD SHALL BE LOCATED A MINIMUM OF 3' FROM ANY STRUCTURE BACK AND SIDE, AND A MINIMUM OF 10' OF CLEARANCE AT THE FRONT OF THE PAD SHALL BE MAINTAINED.

(9) OWNER/CONTRACTOR SHALL BE RESPONSIBLE FOR THE INSTALLATION OF ALL SECONDARY CONDUIT, CABLES AND CONNECTORS FROM THE TRANSFORMER PAD TO THE SERVICE ENTRANCE.

(10) ALL SECONDARY CONDUIT(S) MUST TERMINATE WITHIN THE SECONDARY SIDE OF THE TRANSFORMER VAULT (GENERALLY THE RIGHT THIRD OF THE PAD - APPROX. 18-30" FROM SIDEWALL OF PAD)
 (11) TWO HOLE COMPRESSION CONNECTORS SHALL BE UTILIZED AT THE TRANSFORMER AND MUST BE HAND TIGHTENED BY CONTRACTOR AND LEFT FOR C.E.L. TO MAKE THE FINAL TORQUED CONNECTIONS.
 (12) SPARE CONDUIT SHALL BE INSTALLED TO ALLOW FOR FUTURE MAINTENANCE. THE INSTALLATION SHALL MEET ALL APPLICABLE CODES AND C.E.L. STANDARDS AND APPROVAL.

(13) TWO (2) - 5/8" X 8' COPPER CLAD GROUND RODS SHALL BE DRIVEN 18" BELOW GROUND LEVEL, LOCATED @ THE CORNERS CLOSEST AND FURTHEST FROM PRIMARY OPENING IN THE PAD, AS SHOWN ON THE DRAWING.

(14) A GROUND GRID SHALL BE CREATED BY CONNECTING #2 BARE Cu. IN AN ENVELOPE AROUND THE PAD AND EXTENDING THE CONDUCTOR TAILS 5' ABOVE THE SECONDARY AND PRIMARY OPENING OF THE PAD.

(15) CONTRACTOR TO INSTALL CONCRETE BOLLARDS AROUND TRANSFORMER, IF NECESSARY - LOCATION TO BE DETERMINED BY C.E.L.

(16) C.E.L. MUST APPROVE ALL WORKMANSHIP PRIOR TO ENCASEMENT AND BACKFILLING.

(17) EXCAVATION FOR PAD SHALL BE CARRIED TO A DEPTH OF 12" BELOW BOTTOM OF PAD WALLS. BACKFILL UNDER THE WALLS SHALL BE PLACED IN LAYERS AND COMPACTED WITH MECHANICAL RAMMERS TO NO LESS THAN 95 PERCENT OF THE MAX DENSITY AS DETERMINED BY STANDARD COMPACTION TEST; ASTM D 698.

(18) LOCATION OF CONDUIT MUST BE APPROVED BY C.E.L. BEFORE INSTALLATION.

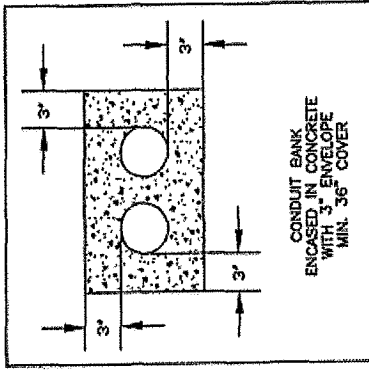
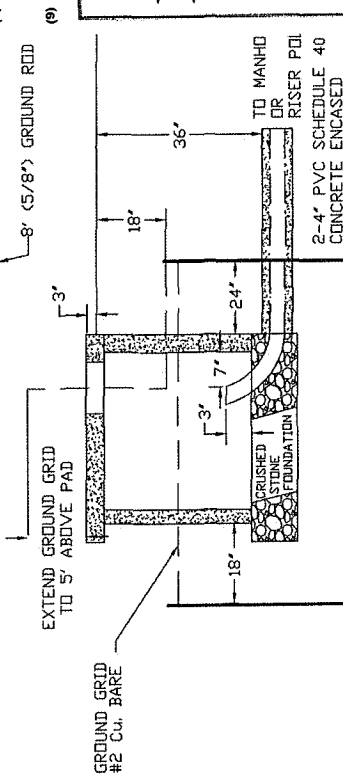
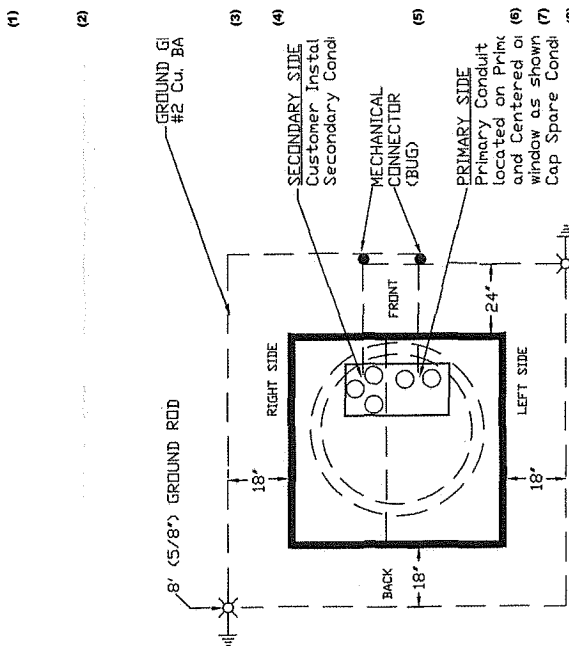

CHICOPEE ELECTRIC LIGHT
 725 FRONT ST., CHICOPEE, MA. 01020

CONSTRUCTION STANDARD FOR SINGLE PHASE TRANSFORMER INSTALLATION

DRAWN BY: J.DENI SCALE: N.T.S. DATE: 8/10/2006
 CHECKED BY:

FIGURE 3-10

NOTES:

- (1) 75 - 500 KVA - INSTALL 76" X 70" X 36" PAD, PER ROTONDO MODEL # P-015 (OR EQUIVALENT)
- (2) 750 - 2000 KVA - INSTALL 84" X 84" X 36" PAD
- (3) PRIMARY CONDUIT - CONTRACTOR SHALL INSTALL 2-4" & 1-2" (optional for Telecom) SCHEDULE 40, CONCRETE (3000 PSI) ENCASED PVC CONDUIT (3" ENVELOPE AROUND CONDUIT) W/ A MINIMUM OF 36" OF COVER, FROM THE POLE OR MANHOLE TO THE PRIMARY SIDE OF THE PAD.
- (4) ALL CONDUIT SHALL BE CLEANED AND SWABBED.
- (5) A 600 LB. PULL STRING SHALL BE PROVIDED IN EACH CONDUIT.
- (6) 1/2" DIA. SWEETWELDS WITH 36" RADIUS SHALL BE INSTALLED @ THE POLE (S.E.L. ENGINEERING WILL APPROVE). ON THE POLE, THE CONDUIT MUST BE TIED UP TO THE POLE USING SCHEDULE 80 CONDUIT WITH THE OTHER CONDUIT CAPPED/PLUGGED. JUST ABOVE THE CONDUIT, THE CONDUIT SHALL ALSO BE CAPPED INSIDE THE TRANSFORMER PAD.
- (7) CONCRETE ENCASEMENT MUST STOP SHORT OF THE POLE - ENCA SE THE COUPLING BETWEEN THE CONDUIT & SWEETWELDS.
- (8) TRANSFORMER PAD SHALL BE LOCATED A MINIMUM OF 3' FROM ANY STRUCTURE BACK AND SIDE, AND A MINIMUM OF 10' OF CLEARANCE AT THE FRONT OF THE PAD SHALL BE MAINTAINED.
- (9) OWNER/CONTRACTOR SHALL BE RESPONSIBLE FOR THE INSTALLATION OF ALL SECONDARY CONDUIT, CABLES AND CONNECTORS FROM THE TRANSFORMER PAD TO THE SERVICE ENTRANCE.
- (10) ALL SECONDARY CONDUIT(S) MUST TERMINATE WITHIN THE SECONDARY SIDE OF THE TRANSFORMER VAULT (GENERALLY THE RIGHT THIRD OF THE PAD - APPROX. 18-30" FROM SIDEWALL OF PAD)
- (11) TWO HOLE COMPRESSION CONNECTORS SHALL BE UTILIZED AT THE TRANSFORMER AND MUST BE HAND TIGHTENED BY CONTRACTOR AND LEFT FOR C.E.L. TO MAKE THE FINAL TORQUED CONNECTIONS.
- (12) SECONDARY CABLES SHALL HAVE SUFFICIENT SLACK TO ALLOW FOR FUTURE MAINTENANCE. THE INSTALLATION SHALL MEET ALL APPLICABLE CODES AND C.E.L. STANDARDS AND APPROVAL
- (13) TWO (2) - 5/8" X 8' COPPER CLAD GROUND RODS SHALL BE DRIVEN 48" BELOW GROUND LEVEL, LOCATED @ THE CORNERS CLOSEST AND FURTHEST FROM PRIMARY OPENING IN THE PAD, AS SHOWN ON THE DRAWING.
- (14) A GROUND GRID SHALL BE CREATED BY CONNECTING #2 BARE CL. IN AN ENVELOPE AROUND THE PAD AND EXTENDING THE CONDUCTOR TAILS 5' ABOVE THE SECONDARY AND PRIMARY OPENING OF THE PAD.
- (15) CONTRACTOR TO INSTALL CONCRETE BOLLARDS AROUND TRANSFORMER, IF NECESSARY - LOCATION TO BE DETERMINED BY C.E.L.
- (16) C.E.L. MUST APPROVE ALL WORKMANSHIP PRIOR TO ENCASMENT AND BACKFILLING.
- (17) EXCAVATION FOR PAD SHALL BE CARRIED TO A DEPTH OF 12" BELOW BOTTOM OF PAD WALLS. BACKFILL UNDER THE WALLS SHALL BE CLEAN GRAVEL/STONE AND PLACED IN 2-3" LAYERS AND COMPACTED W/MECHANICAL TAMPERS TO NO LESS THAN 95 PERCENT OF THE MAX DENSITY AS DETERMINED BY STANDARD COMPACTION TEST, AASHTO OR ASTM, D.698.
- (18) LOCATION OF CONDUIT MUST BE APPROVED BY C.E.L. BEFORE INSTALLATION.

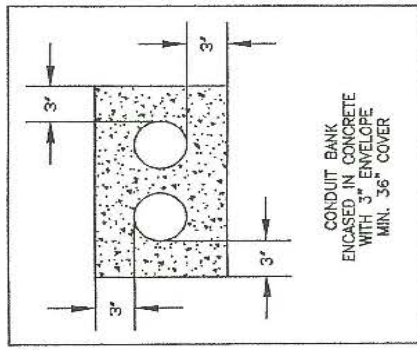
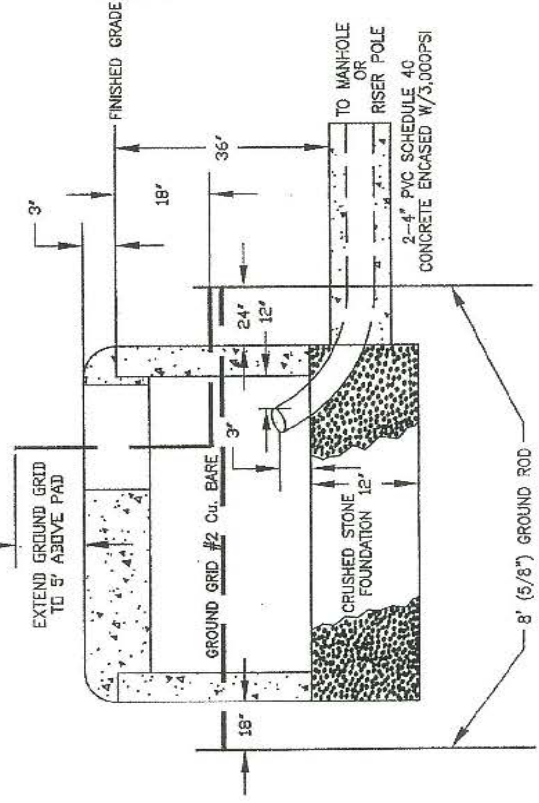
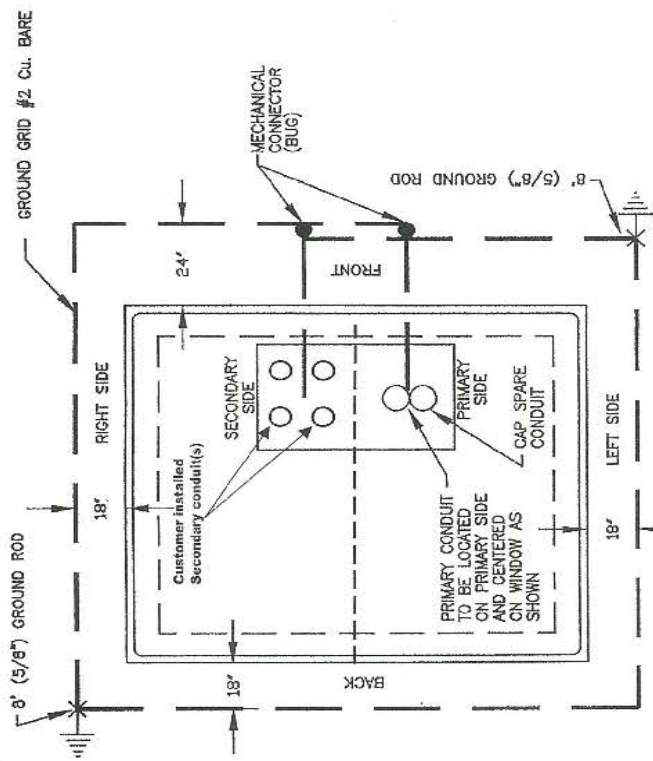



CHICOPEE ELECTRIC LIGHT
725 FRONT ST., CHICOPEE, MA. 01020

**CONSTRUCTION STANDARD FOR A
THREE PHASE PAD MOUNT TRANSFORMER
INSTALLATION**

DRAWN BY: D. O'NEIL	SCALE: N.T.S.	DATE: 11/22/95
CHECKED BY:		
REVISED 2/23/2021		REVISION #3

TYPICAL HANDHOLE INSTALLATION

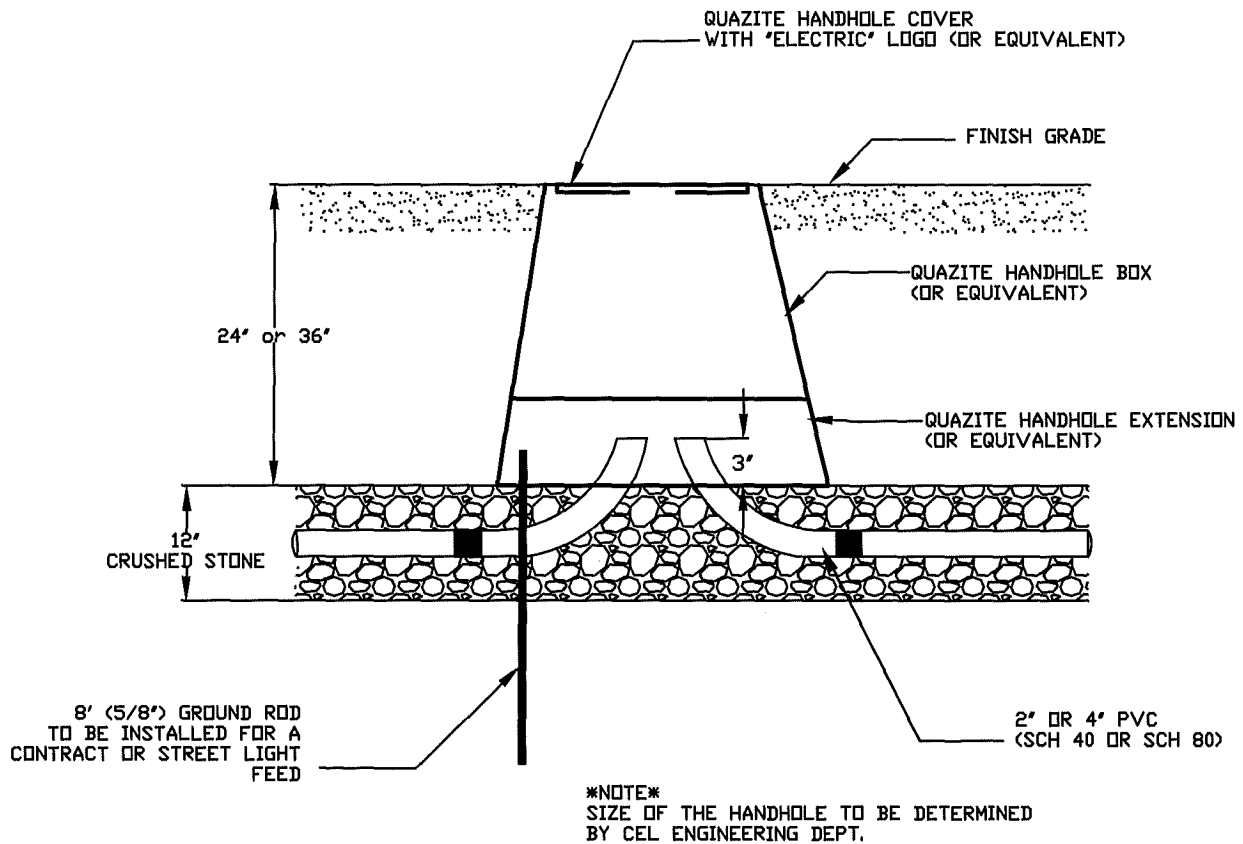
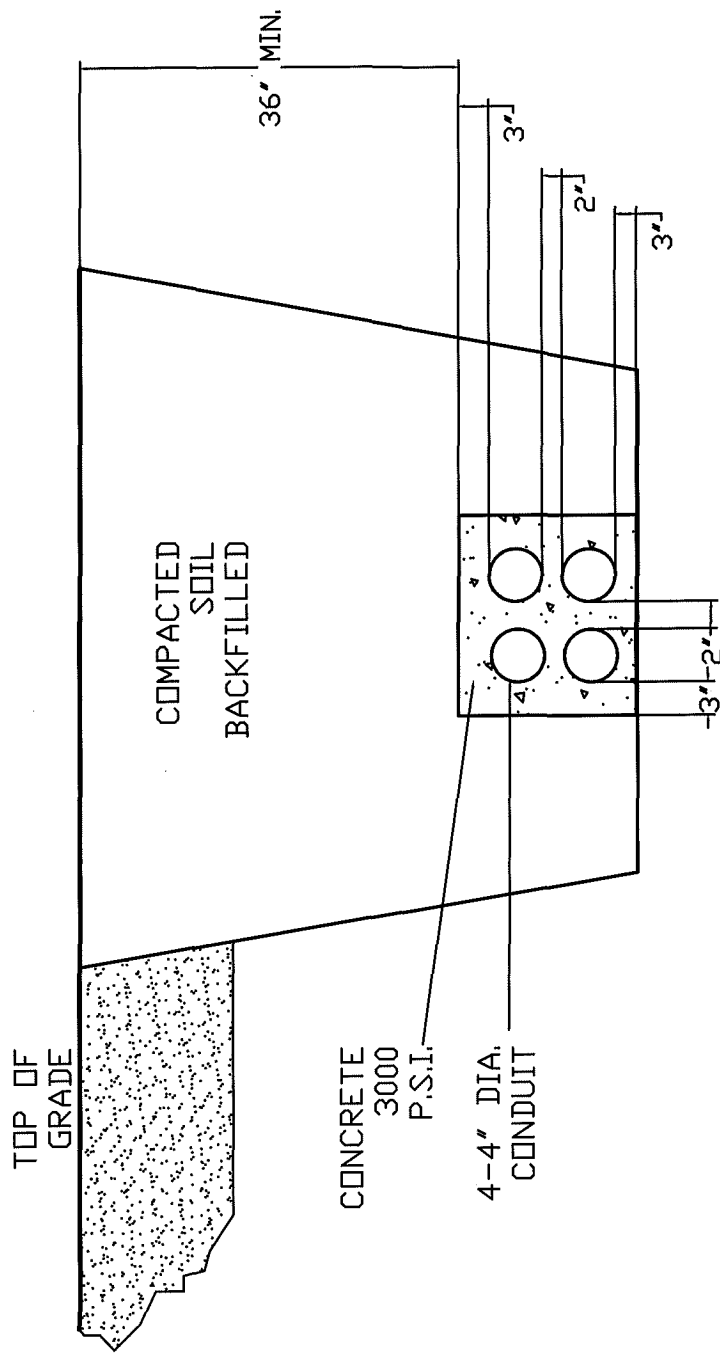
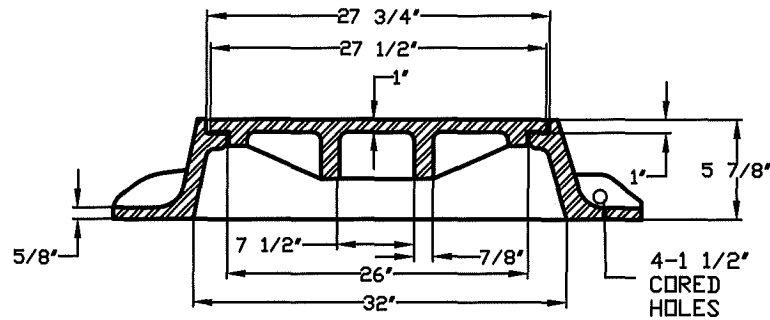
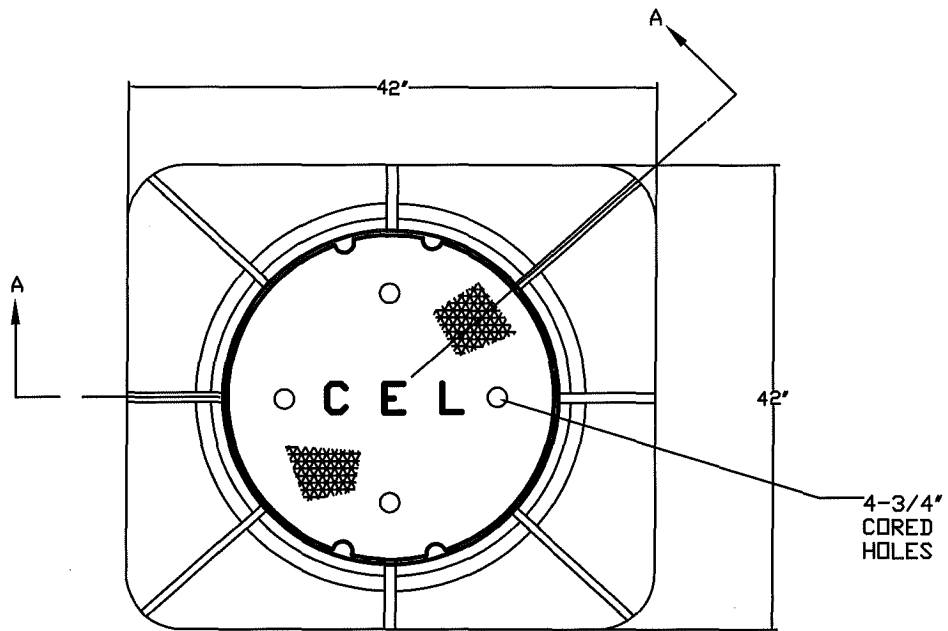

FIGURE 3-12



TYP. UNDERGROUND CONDUIT
ENCASEMENT 4-BANK
FIGURE 3-13

NOTE: CEL COVER BY E.L. LEBARON FOUNDRY
BROCKTON MA.
#LE-276-2



SECTION: A-A

TYPICAL MANHOLE COVER
AND FRAME

FIGURE 3-14

TYPICAL SERVICE MANHOLE
 (4'X4', 4'X6')
 (DIAGRAM SHOWS A 4'X4' MANHOLE)

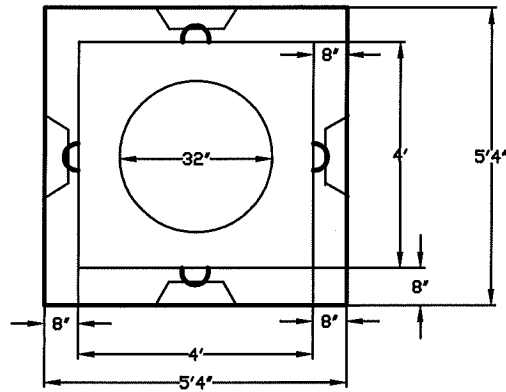

PLAN VIEW

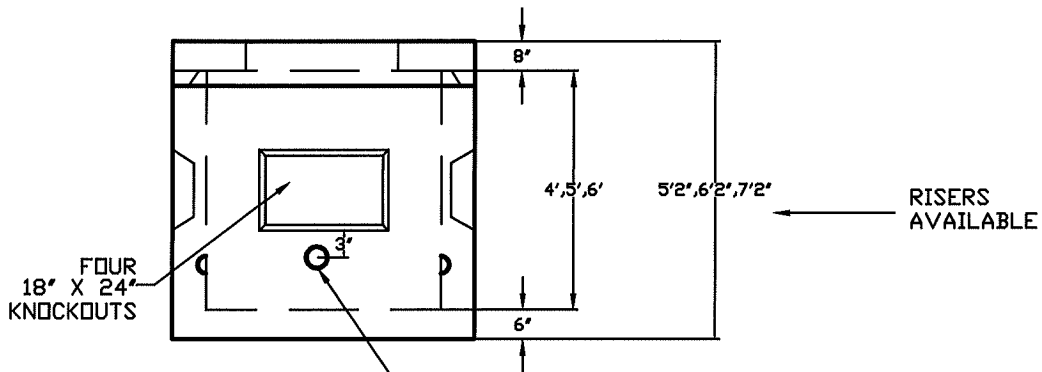

ELEV. VIEW

- ***NOTE***
- 1-CONSTRUCTION JOINTS SEALED WITH 1" DIA. ASPHALT ROPE TAR WHERE APPLICABLE.
 - 2-H20 DESIGN FOR HEAVY TRAFFIC AREAS.

FIGURE 3-15

TYPICAL FULL SIZE MANHOLE
(5'X10', 6'X10', & 6'X12')

(DRAWING SHOWS A 5'X10' MANHOLE)

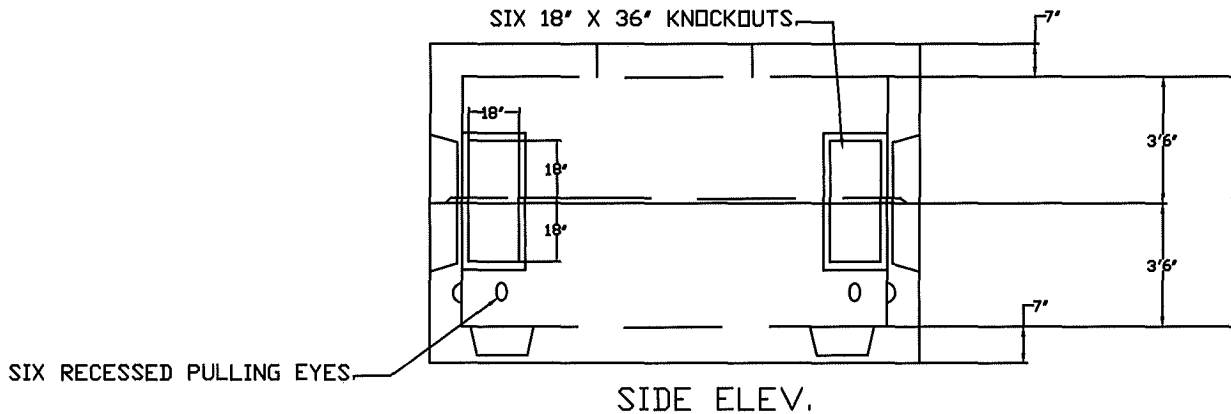
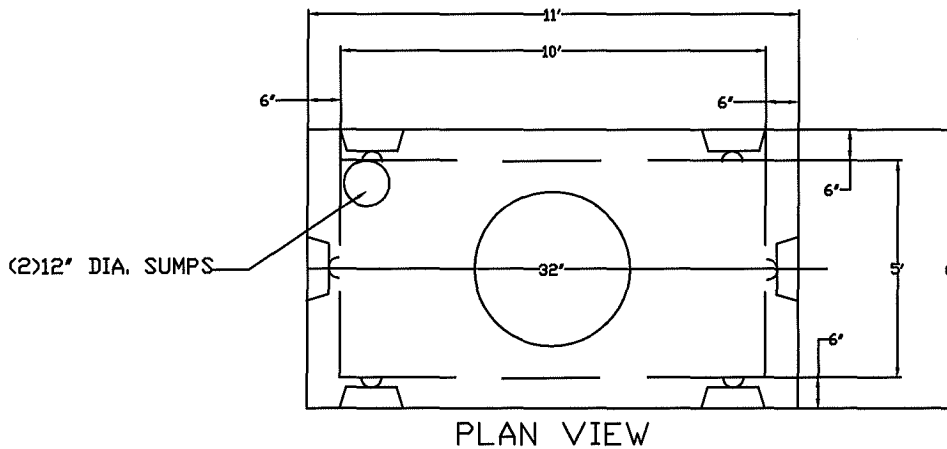

NOTE

1-CONSTRUCTION JOINTS SEALED
WITH 1" DIA. ASPHALT ROPE TAR
WHERE APPLICABLE.

2-H20 DESIGN FOR HEAVY TRAFFIC
AREAS.

FIGURE 3-16

CHAPTER 4

METER INSTALLATIONS

There are three basic ways to measure electricity consumption:

- a. Small and medium services are metered directly using direct-connect meters.
- b. Large services are metered using current transformer cabinet, current transformers (CTs) and instrument-rated meters.
- c. Very large services are metered at switchboards housing CT's and instrument-rated meters.

The customer's electrician provides and installs all equipment beyond the point of delivery: meter sockets, cabinets and enclosures, connection lugs, conduit, grounding, protection devices, and wiring from the socket to the load.

CEL provides and installs the meter, current transformers, and local wiring associated with the meters and CTs.

4.1 LOCATING THE METER

It is in the mutual interest of the customer and CEL to install the meter in a location suitable for meter reading, testing, repair and removal. Meter locations are subject to approval by CEL's Meter Department.

4.1.1 METER LOCATIONS:

- a) All residential meters shall be outside on the front or front corner of the house. (The front of the house is considered to be the side facing the city or private roadway).
- b) Commercial meters shall normally be located outdoors.
- c) Meters shall be grouped together to keep the number of meter locations to a minimum (normally one location per property).
- d) Instrument transformer enclosures may be located indoors in a suitable area readily accessible by CEL personnel. (The meter socket shall normally be located outdoors).
- e) Single meters are to be installed five feet from the center of the meter to finish grade.
- f) Multiple meters are to be installed with the upper meter to be no higher than six feet from the center of the meter to finish grade, and the lower meter four feet (minimum) from the center of the meter to finish grade.

4.1.2 METER SHOULD NOT BE LOCATED AT FOLLOWING LOCATIONS:

- a) Behind a fence or enclosure.
- b) In areas subject to being fenced or enclosed such as patios, pool areas, decks, porches and backyards.
- c) Where shrubs or landscaping could obstruct access to the meter.
- d) In an unsafe or inconvenient location, such as above a stairway or window well.
- e) On a mobile structure such as a houseboat or mobil home.
- f) Outside bedrooms or bathrooms and near doors and windows, to respect customer privacy.
- g) In a location with abnormal temperature vibration, corrosive air, or excessive noise (Example: Motors, Compressor rooms, etc.)

- h) On a pole owned by CEL or another utility
- i) In areas subject to damage from a vehicle

The requirements listed above also apply to meters for outbuildings such as detached garages, barns, shops, storage buildings, pump houses, and other structures that do not provide living space.

Note: If an additional meter is required for a second structure (such as a garage, barn, etc.) on the same piece of property, the original meter and the new meter will be mounted side by side on either the existing structure or on the new structure with one electric service riser servicing both meters.

4.1.3 METERS LOCATED INSIDE THE ELECTRICAL ROOM

If a single meter or multiple meters for residential/commercial services are approved by CEL to be located inside an electrical room, the following conditions are required:

- a) Contain only power and communication equipment
- b) Not to be used for storage
- c) Be accessible during normal business hours
- d) Be well lit
- e) Be accessible through a door that opens directly to the outside, or with prior approval by CEL, opens directly to the lobby of the building's main entrance. If the facility could be locked during normal business hours (such as a school, church or meeting hall), the electrical equipment room door must open directly to the outside. The door must be at least two feet, eight inches wide and six feet, eight inches high, and open outward. The exterior of the door must have a sign saying "Electrical Room". The customer must supply CEL with a key to the door.
- f) Must provide adequate workspace and walkways (refer to figure 4-1, Page 58)

4.2 DUCT BOXES

Where required by CEL a steel duct box is to be provided and installed by the customer's electrical contractor. It is to be rigidly and permanently secured immediately adjacent to the wall entrance of the conduit, at a designated location inside the building. It will contain the incoming duct(s) and the splices which are to be made by CEL between the service lateral conductors and the service-entrance wiring.

The size of the duct box to be used will be determined by the number of sets of service-entrance conductors to be contained within the box and by the rating of the largest switch or circuit breaker. The following sizes are based on the use of copper conductors (NOTE: When aluminum service-entrance conductors are installed, the duct box shall be the next largest size over that specified for copper conductors):

Rating of Largest Switch or Circuit Brkr <u>Amperes</u>	<u>Phase</u>	Duct Box Size <u>(Inches)</u>	Duct Box <u>Type</u>	Service Entrance Equipment Supplied From <u>Duct Box</u>			
				<u>1</u>	<u>2</u>	<u>3</u>	<u>4 or More</u>
Up to 100	1	12 X 12 X 12 Deep	A	A	A	B	C
200	1	12 X 18 X 12 Deep	B	B	*	*	*
100 - 200	3	12 X 18 X 12 Deep	B	B	C	C	D
400	1	18 X 24 X 18 Deep	C	C	*	*	*
400	3	18 X 24 X 18 Deep	C	C	*	*	*
600	1	24 X 30 X 18 Deep	D	D	*	*	*
600	3	24 X 30 X 24 Deep	E	E	*	*	*
800	1	24 X 30 X 24 Deep	E	E	*	*	*
800	3	30 X 36 X 24 Deep	F	F	*	*	*
1000	1	30 X 36 X 24 Deep	F	F	*	*	*
1000	3	36 X 42 X 24 Deep	G	G	*	*	*
1200	1	36 X 42 X 24 Deep	G	G	*	*	*
1200	3	42 X 48 X 24 Deep	H	H	*	*	*
1600	1	42 X 48 X 24 Deep	H	H	*	*	*
1600 - 2000	3	42 X 48 X 24 Deep	H	H	*	*	*

NOTE: * Consult City of Chicopee's Wiring Inspector for required Size Box

Duct boxes are to be mounted horizontally and located such that the duct(s) into the box shall be in a corner to allow for the most practical means for forming the conductors in the box and make the splices.

The Customer's service - entrance conductors coming into the box should be kept clear of the incoming supply duct(s).

4.3 CLEARANCES AROUND THE METER

Meter clearances are measured from the center of the meter socket, or from the center of the face of the meter. The meter socket shall be installed between 4.5' and 5.5' above finished grade (5' preferred). A minimum 3 feet square working space shall be maintained in front of the meter. This space must be permanently free of all obstructions, including landscaping.

Additionally, Allow 3 feet of clearance from a gas meter, and 3 feet from windows or doors for customer privacy. (Refer to Figure 4-1, Page 58).

4.4 INSTALLATION FOR AN APARTMENT BUILDING

Figure 4-2 on Page 59 shows a typical multiple meter single-phase installation for a multifamily building. If the installation has more than six meters, a main disconnect is required.

4.5 INSTALLATION FOR AN OFFICE BUILDING

This is a typical multiple-meter three-phase installation for services of 200 amps or less (120/208V). If the installation has more than six meters, a main disconnect is required. The clearances shown for this office installation also applies to factory-built multiple meter panels, meters must be a minimum of 4 feet above the floor, and maximum of 6 feet. (Refer to Figure 4-3, Page 60)

4.6 METERING TO MULTIPLE MOBILE HOMES

Figure 4-4, Page 61 shows a single-phase self-contained metering to multiple mobile homes. If the meter structure is installed in a vehicle traffic area, install a guard post. (Refer to Figure 3-9, Page 37 for guard post requirements.)

4.7 GENERAL REQUIREMENTS FOR METER SOCKETS

Meter sockets must meet the following requirements:

- a. Ringless with sealing provisions or Ring-type, to accept a meter sealing ring
- b. Rated NEMA 3R – for exterior use and rain tight
- c. Installed level, plumb, and fastened securely to a rigid structure
- d. All unused openings in the enclosure, closed with plugs and secured tightly from the inside.
- e. Covered and sealed with a transparent cover, if live lines are installed
- f. Not jumpered to provide power
- g. Acceptable to CEL and Underwriters Laboratories (UL)
- h. For residential meter sockets, a manual bypass socket is not required
- i. For all three phase self contained meters, a manual bypass must be provided

4.7.1 Sockets For Residential And Temporary Services

Most residential services, and all temporary services (120/240V), use a socket with four jaws and a ground terminal.

- a. Figure 4-5a on Page 62 shows a typical meter socket used on an overhead service.
- b. Figure 4-5b on Page 62 shows a typical meter socket used on an underground service

4.8 GROUNDING A METER SOCKET

Grounding the meter socket protects personnel and equipment in the event of an external line surge, lightning strike, or accidental contact between phase and neutral conductors. This is done by attaching a ground wire to the neutral terminal at the meter socket and using a minimum No. 6 copper wire (or No. 4 aluminum wire) to connect the terminal to a rod driven into the ground. A ground rod should be installed a few feet away from the meter socket - avoid installing the ground rod in disturbed earth that has a relatively higher resistance. After connecting the ground wire and rod, if the resistance to earth is more than 25 ohms, install a second ground rod at least 6' away from the first. Above all, follow the requirements of the Mass Electrical Code.

After installation, leave the connection to the ground rod visible for electrical inspection. For safety, the top of the ground rod should be flush with or below ground level. Factors that affect the ability of the ground rod to dissipate power surges include:

- a. The type soil at the site. Examples: clay soil has high conductivity that is good; gravel has low conductivity that is bad.
- b. The condition of the soil. Damp is good, contact with the water table is very good, high salt content is good, frozen soil is bad.
- c. The size of the ground rod. The longer the rod and the larger the diameter, the better.
- d. The ground rod material. Copper is better than steel. Copper-clad steel is better than steel alone.
- e. The resistance across clamps and connections. Note: The integrity of these connections tends to deteriorate with time.

4.9 METER INSTALLATION TIPS

4.9.1 Cable Runs

- a. Metered circuits and un-metered circuits must not be intermixed in raceways or enclosures.
- b. Customer equipment is not allowed inside a meter enclosure or CT cabinet
- c. Customer load monitoring equipment, if installed, must be on the load side of the meter.
- d. Line-side conductors are connected to the top terminals of the meter socket.
- e. After the installation is complete, make these mechanical checks: Conductors are not under undue strain on their terminals, connections are tight, terminals are rated for the size of conductor used, strands have not been removed to make conductors fit under-sized terminals.

4.9.2 Labeling

For multi-meter installations, each meter must have a permanently engraved metal or hard plastic label that identifies the billing address.

4.9.3 Protection

- a. Meter sockets equipped with a manual bypass are not required for single-phase (120/240V) residential services.
- b. Meter sockets equipped with a manual bypass are required for all commercial services.
- c. The ampacity rating of the main circuit breaker, or safety switch, must not exceed the maximum rating of the meter socket. For three-phase service, if the marked continuous ampacity exceeds 320 amperes, the customer must install CT metering.
- d. All service equipment must be metered ahead of the disconnect switch, except in special situations approved by CEL.
- e. Current limiting fuses, which protect the customer's electrical system from excessive current, must be located in the customer's service panel or in a separate enclosure between the socket and the panel.
- f. Ground and bond all meter sockets, enclosures, and conduit in accordance with Mass. Electrical Code. Connect the neutral conductor to the neutral terminal in the socket.

- g. When metering equipment is installed in a location where it might be struck by a vehicle, the customer must install and maintain a guard post. (Refer to Figure 3-9 on Page 37 for guard post requirements)

4.10 DIRECT CONNECT METERS

Direct connect meters carry full load current and connect directly across full line voltage. Direct connect meters are also called self-contained meters. Direct-connect, socket-type meters are installed on following type of services:

- a. Single Phase, up to 320 amps
- b. Three Phase, up to 320 amps, and with motors up to 60 hp for 120/208 service, and up to 200 amps, and with a motor up to 125 hp for 277/480 volt service

The following is a list of services metered using direct - connect meters:

- a. Single-Phase 120/240V 3 wire (Figure 4-6a, Page 63)
- b. Single-Phase 120/208V 3 Wire Network (Figure 4-6b, Page 63)
- c. Three Phase 120/208V, 4 Wire WYE (Figure 4-6c, Page 63)
- d. Three Phase 277/480V, 4 Wire WYE (Figure 4-6d, Page 63)

Services larger than these are metered using instrument-rated meters with current transformers.

4.11 CURRENT TRANSFORMER METERING

Current transformers are used with instrument-rated meters, to meter single-phase and three phase services greater than 320 amps. Smaller services use direct-connect metering.

The customer's electrician provides and installs all equipment beyond the point of delivery including, but not limited to the meter sockets, cabinets and enclosures for the meter, pre-wired test switch, connection lugs, conduit, grounding, protection equipment, and wiring from the load to the CT mounting base.

CEL provides the current transformers (CT's), installs the meter, and wiring associated with the meter, and CTs. The customer's electrician is responsible for installing the CT's (white dot on the CT's to the line side of the service) and properly torquing buss bar or lug connections.

NOTE: The customer's electrician is responsible for the installation of all secondary conductors from the pad-mounted transformer to the CT cabinet, and installing the CT's. Refer to Chapter 3, Section 3.4.3, Page 27.

The following is a list of services metered using instrument-rated meters and current transformers:

- a. Single-phase, 120/240V, 3 wire ((Figure 4-7a, Page 64)
- b. Three Phase, 120/208V 4 wire wye (Figure 4-7b, Page 64)
- c. Three-phase, 277/480V, 4 wire wye (Figure 4-7c, Page 64)

4.11.1 Current Transformer Cabinet

The customer provides and installs a cabinet for the current transformers, and the conduit between the CT cabinet and the meter enclosure. The CT cabinet is metal, weather tight, NEMA 3R rated, and securely mounted on a rigid surface plumb in both directions. The cabinet is to have a side-hinged, sealable door. When open, the door must not block a safe exit. The top of the cabinet must be no higher than 7 feet above the floor, and the bottom of the cabinet must be at least 6 inches above the floor. The dimensions of the CT cabinet are:

<u>Service</u>	<u>Number of CTs</u>	<u>Width</u>	<u>Height</u>	<u>Cabinet Depth</u>
Single-Phase, 400-800 amps	2	30"	48"	11"
Three-Phase, 400-800 amps	3	36"	48"	11"
Over 800 amps	Requires Switchboard Metering			

The location of the CT cabinet is subject to the approval of CEL Meter Dept. Inside the cabinet, the customer installs a mounting base for the CTs and a neutral lug. A single-phase mounting base is used if the service is single-phase, a three-phase mounting base is used if the service is three-phase. The base has two cable termination bolts on the line and the load side of each phase, and two bolts on the neutral bus.

The CT cabinet contains only the main service conductors. A maximum of four main service conductors may be served from the load side of each termination bolt, as long as the lugs are not stacked and they do not restrict mounting the CTs. Use "stair step" lugs if more than two conductors are terminated at a CT. If the CT cabinet is installed in a vehicle traffic area, install a guard post. (Refer to Figure 3-9 on Page 37 for guard post requirements).

4.11.2 Meter Socket, Enclosure And Conduit

The distance between the meter socket enclosure and the CT cabinet is not less than 10 inches and not more than 50 feet. Mount the two enclosures as close together as feasible.

Meter Socket and Enclosure for Single-Phase Circuits

For single-phase circuits, the customer's electrician provides and installs a 6 terminal meter socket with a pre-wired test switch, with conduit between the meter enclosure and the CT Cabinet. (Refer to Figure 4-8, Page 65)

Meter Socket and Enclosure for Three-Phase Circuits

For three-phase circuits, the customer's electrician provides and installs a 13-terminal meter socket with a pre-wired test switch, with conduit between the meter enclosure and the CT cabinet. (Refer to Figure 4-9, Page 66).

4.11.3 Conduit

For conduit, use rigid steel, rigid PVC plastic (Schedules 40 or 80), or IMC/EMT conduit. Flex conduit is not permitted. When metallic conduit is used, provide grounding bushings at each end. When PVC conduit is used, install a green insulated bonding jumper in the conduit. 1-1/4 -inch conduit or larger is required, with proper fittings and bushings to protect metering conductors. The conduit enters the meter enclosure adjacent to the test switch. A pull string is required if the conduit is over 25 feet. Conduit bends must not exceed 360 degrees total.

4.11.4 Mounting Base for Current Transformers, Single-Phase Services

The customer installs this CT mounting base in the CT cabinet for single-phase services. This mounting base accepts bar-type current transformers, only.

For overhead or underground services, the customer electrical contractor connects the line and load conductors to the terminals on the mounting base.

The mounting base must be rated for fault current of 50,000- amperes, minimum.

Based on EUSERC 328B (Refer to Figure 4-10, Page 67)

4.11.5 Mounting Base for Current Transformers, Three-Phase Services

The customer installs this CT mounting base in the CT cabinet for three-phase services. This mounting base accepts bar-type current transformers, only.

For overhead or underground services, the customer electrical contractor connects the line and load conductors to the terminals on the mounting base.

The mounting base must be rated for fault current of 50,000 amperes, minimum.

Based on EUSERC 329B (Refer to Figure 4-11, Page 68)

4.12 SWITCHBOARD METERING

A custom-built switchboard is required for services over 800 amperes. Switchboard metering may also be used on 201-800 amp services, at the customer's option. The switchboard will include the switchboard service section, current transformer (CT) mounting base, and a means for locking the CT cabinet with independent access by CEL. The customer must submit one set of drawings to CEL for approval, prior to shipment of the switchboard from the manufacturer.

The point of delivery must be no more than 5 feet vertical or horizontal inside the building from the point of entrance. Locate the metering compartment on the supply side off the main switch or breaker, with the CTs in a CT compartment. The meter socket and test switch will be installed outside the building less than 50 feet from the CT compartment. The space below this compartment's barrier may be used as the main switch (breaker) compartment, or a load distribution compartment, or a bottom-fed terminating pull section. CEL will own, provide, and install the meter and related wiring between the meter and CT's. CEL will provide the CT's and the electrical contractor will install the CT in the CT cabinet. CEL is responsible for the wiring between the CTs and the meter.

Mount each socket outside the building and connect it to the switchboard with approved conduit.

(Refer to Figure 4-8, Page 65 for the 6-Terminal Socket for single-phase services using CTs)

(Refer to Figure 4-9, Page 66 for the 13-Terminal socket for three-phase services using CTs)

Switchboard Meter Installation

A typical switchboard meter installation is show in Figure 4-12, Page 69, with the meter mounted outside the building

4.13 OFF-PEAK METERING

In order to qualify for off-peak metering in an electrically heated home with hot water tank, a preliminary and final inspection will be performed by CEL's Engineering Department, using the checklist shown below. Should the home pass the inspection, CEL's Meter Department will inspect the meter socket and hot water tank to verify the meter socket and hot water tank are wired to CEL Specifications (Refer to Figure 4-13, Page 70 or Figure 4-14, Page 71, as applicable). If the installation meets CEL standards, the customer shall sign for the off peak meter and the off-peak meter will be installed.

OFF-PEAK (ELECTRIC HEAT) INSPECTION CHECKLIST

Preliminary Inspection	<u>Manuf. Marking</u>
a. Outside Wall – 4" Stud 3 – 5/8" R13 Insulation with vapor barrier	4 Brown Lines
b. Outside Wall – 6" or 6-1/4" R-19 Insulation with vapor barrier	5 Brown Lines
c. Inside Wall-4" Studs 3-1/2" R-11 Insulation (Cellar Stairway)	3 Brown Lines
d. Underneath the steps to the 2 nd floor 3-1/2" R-11 Insulation	
e. All exhaust fans to be duct to the outside	
f. Cathedral ceilings with proper vents for 9-1/2", R-30 insulation	
g. Attic has proper venting, high or low, or cross air movement	
h. Proper vents around ceiling edges near soffit.	
i. Floor overhang for 9-1/2" R-30 Insulation	
<u>Final Inspection</u>	
a. Blown in Ceiling insulation R-30	14" Minimum
b. Storm Doors or insulated Metal Doors	
c. Storm Windows or insulated Glass (Themopane or welded glass) windows.	
d. Standard Electric Baseboard Sizes	Canadian Baseboard Sizes For
<u>240 Volts</u>	<u>240 Volt (Sentinel)</u>
1-2' – 500 Watts	1-27" – 500 Watts
1-3' – 750 Watts	1-39" – 750 Watts
1-4' – 1000 Watts	1-48" – 1000 Watts
1-5' – 1250 Watts	1-57" – 1250 Watts
1-6' – 1500 Watts	1-66" – 1500 Watts
1-8' – 2000 Watts	1-7'-9" – 2000 Watts or 2250 Watts
1-10' – 2500 Watts	1-9'-6" – 2500 Watts
Approx. electric baseboard size – take square feet of a room and multiply by 10	
e. Range and Dryer Electric outlets	
f. 200 AMP main breaker in the distribution panel	
g. Hot Water Tank, 80 or 120 gallons and recorded upper and lower heater Elements (4,500 Watt)	
h. Floor Insulation for 3-1/2", R-11	

METER SOCKETS

Meter sockets come in six configurations. The services used with each type are shown here.

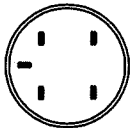
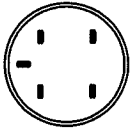
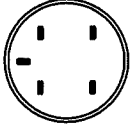
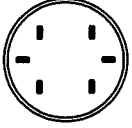
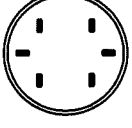
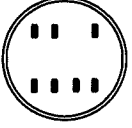
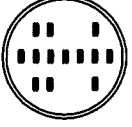
SOCKET	VOLTAGE	CURRENT	COMMENT
For single-phase circuits:			
	120/240V, 3-WIRE	UP TO 200 AMPS	Direct-connect socket
	120/208V, 3-WIRE	UP TO 200 AMPS	Direct-connect socket
	120/240V, 3-WIRE	201 TO 320 AMPS	Direct-connect 320A socket
	120/240V, 3-WIRE	Above 320 AMPS	With CTs
	120/240V, 3-WIRE (For Elect. Heat)	200 AMPS	Without CTs
For three-phase circuits:			
	120/208V, 4-WIRE 277/480V, 4-WIRE	UP TO 320 AMPS UP TO 200 AMPS	Direct-connect socket
	120/208V, 4-WIRE 277/480V, 4-WIRE	Above 320 AMPS Above 320 AMPS	With CTs

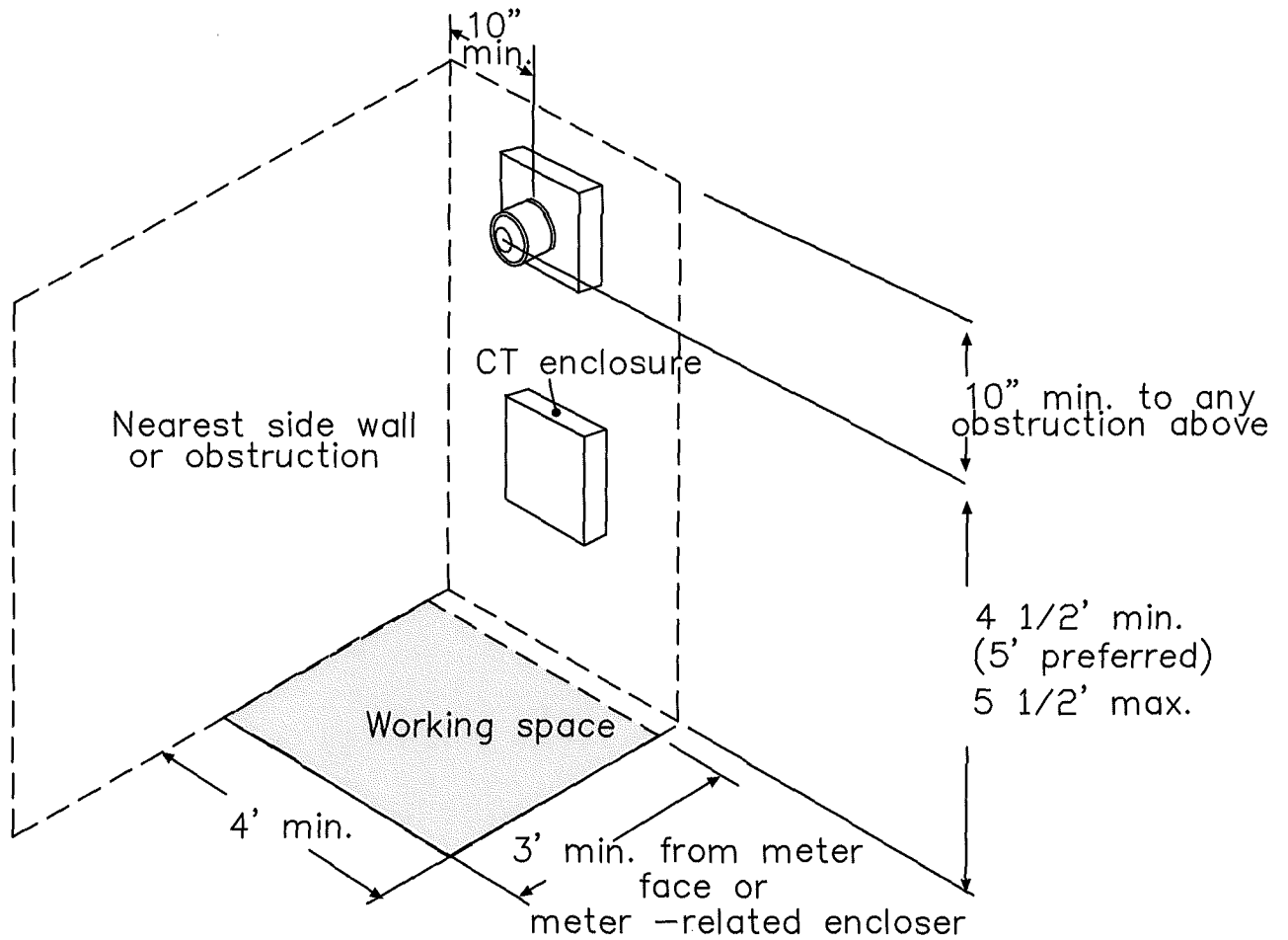

*WORKING SPACE SHOULD BE KEPT CLEAR OF SHRUBS, TREES, DEBRIS, PLANTS, FENCES, AND OTHER STRUCTURES.

CLEARANCES AROUND THE METER
FIGURE 4-1

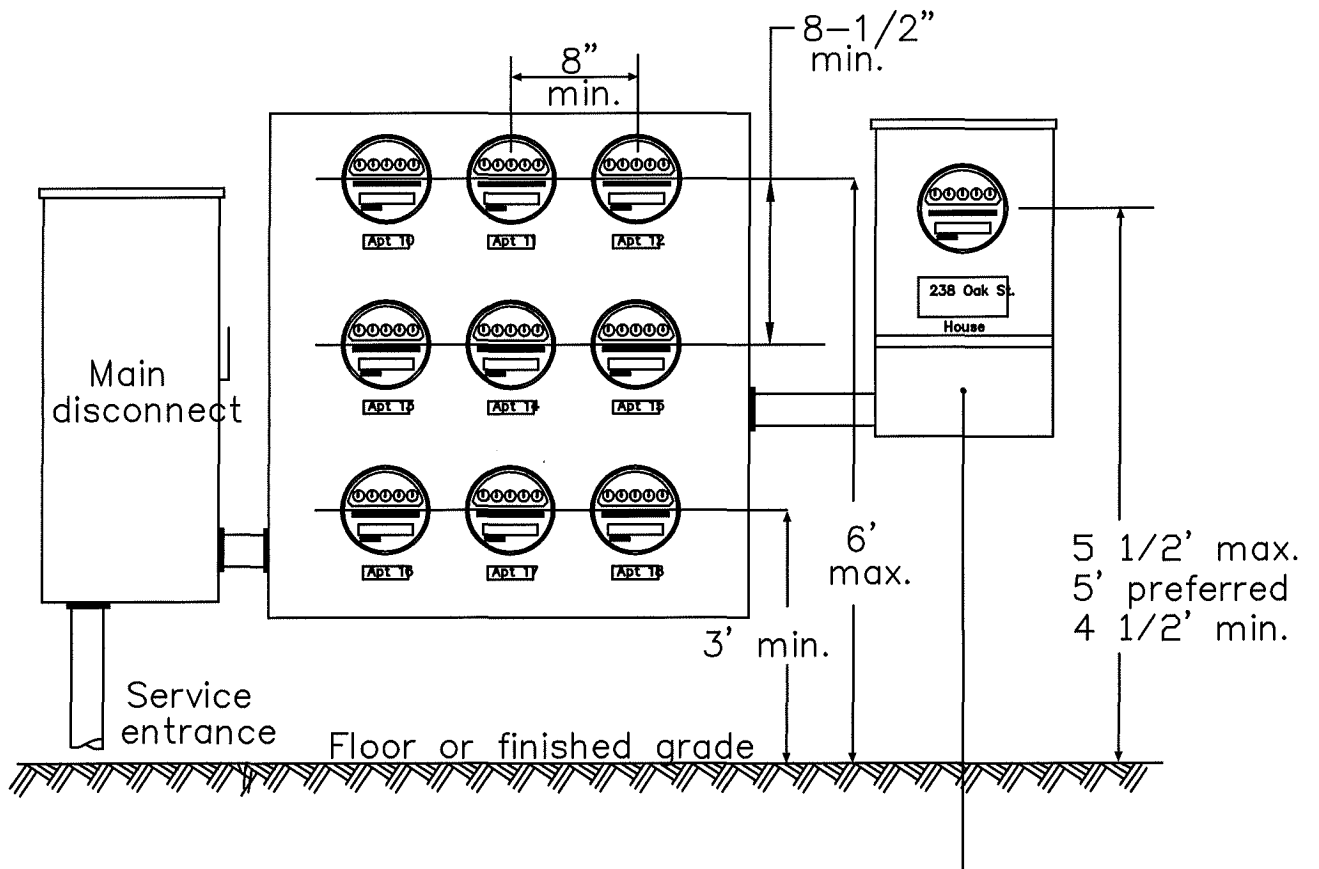

NOTE: HOUSE METER SOCKETS, NO MANUAL BYPASS REQUIRED FOR SINGLE PHASE RESIDENTIAL METERS (SINGLE OR MULTI-FAMILY SERVICES)

INSTALLATION FOR AN APARTMENT BUILDING
FIGURE 4-2

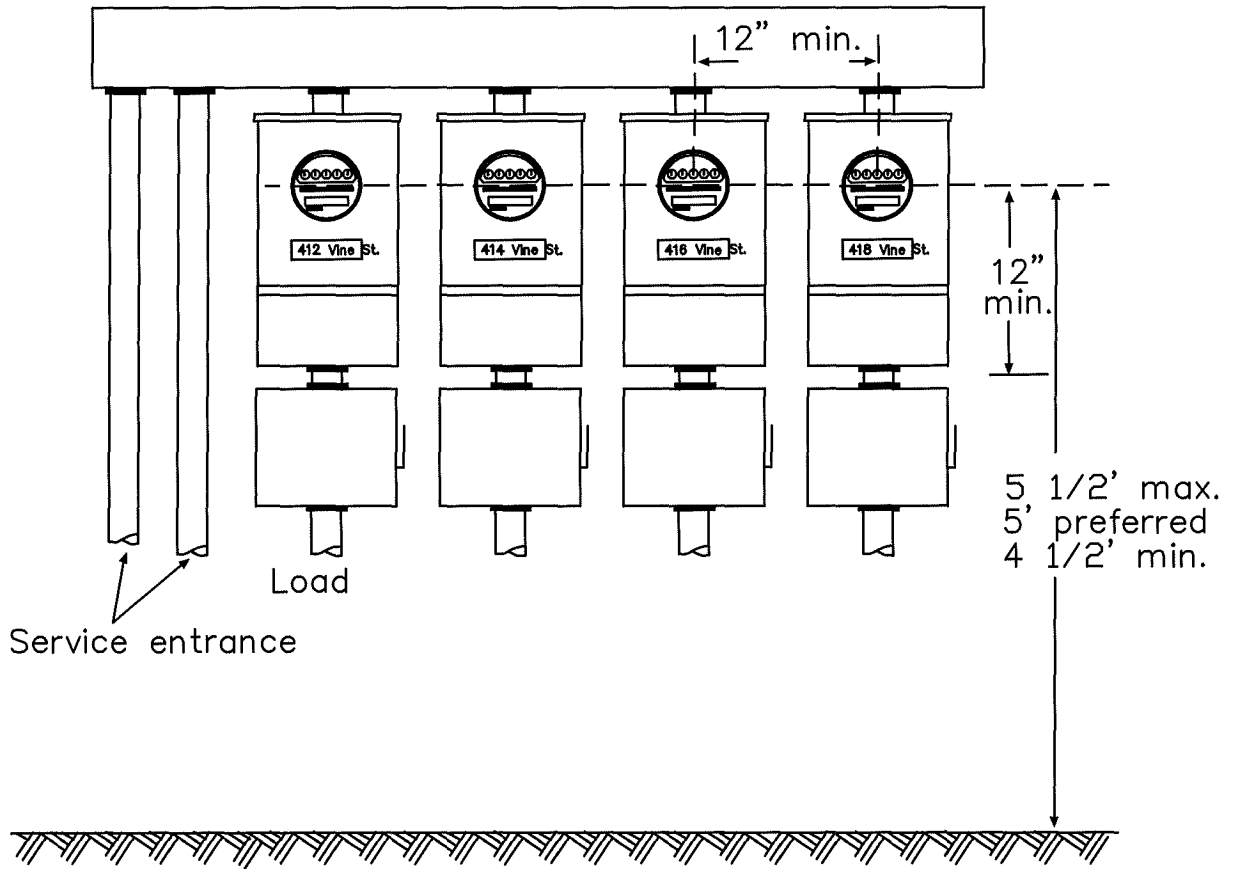

MULTI-METER THREE PHASE 200 AMP OR LESS (120/208V)
FIGURE 4-3

KEY

1. PAINTED METERBOARD, 3/4" EXTERIOR PLYWOOD
2. UPPER EDGE TRIMMED TO PREVENT SEEPAGE INTO LAMINATIONS
3. PRE-BUSSED, GANG METER SOCKETS MARKED INSIDE AND ON COVER OF SOCKET WITH MOBILE HOME IDENTIFICATION. METER SOCKETS MUST HAVE FIFTH TERMINAL KIT INSTALLED. USE A #12 COPPER WHITE INSULATED CONDUCTOR BETWEEN THE FIFTH JAW IN THE 9 O'CLOCK POSITION AND THE NEUTRAL BAR.
4. MINIMUM 6" SPACE BETWEEN METER SOCKET AND SERVICE EQUIPMENT
5. SUITABLE SUPPORTS TO BE GALVANIZED STEEL IN CONCRETE OR MINIMUM 6"X 6" TREATED WOOD
6. WEATHER PROOF JOINT
7. SERVICE EQUIPMENT 200 AMPS OR LESS FOR EACH MOBILE HOME MARKED WITH MOBILE HOME IDENTIFICATION
8. 4" SCH. 40 (OR AS REQUIRED BY CODE) PVC, GALVANIZED IMC, OR RIGID STEEL CONDUIT, REFER TO CHAPTER 3, PAGES 23 (INSTALLING AN UNDERGROUND SERVICE OPTION 1&2).
9. DRIVEN GROUND ROD INSTALLED AND BONDED TO NEUTRAL

NOTE: GROUND AT SERVICE EQUIPMENT IN ACCORDANCE WITH THE MASS. ELECTRICAL CODE.

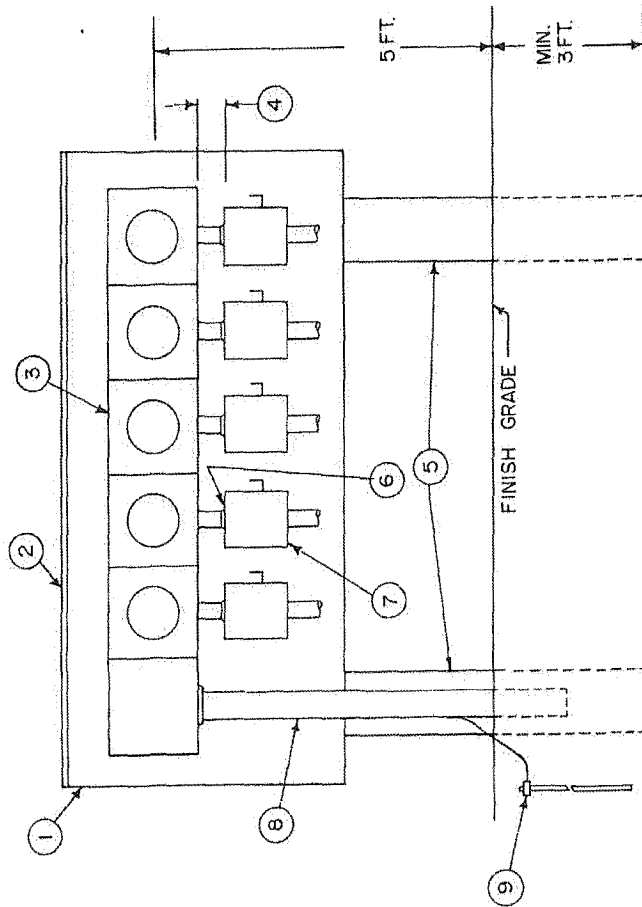

CHICOPEE ELECTRIC LIGHT
725 FRONT ST. CHICOPEE, MA.

SINGLE PHASE SELF-CONTAINED METERING
TO MULTIPLE MOBILE HOMES

DRAWN BY: PSB
CHECKED BY:

SCALE:
DATE: 5-26-92

B-

FIGURE 4-4

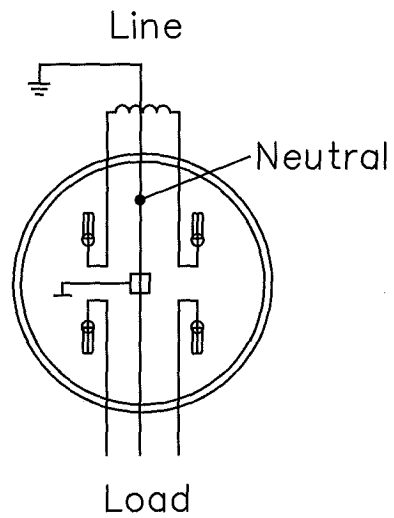

OVERHEAD SERVICE
FIGURE 4-5a

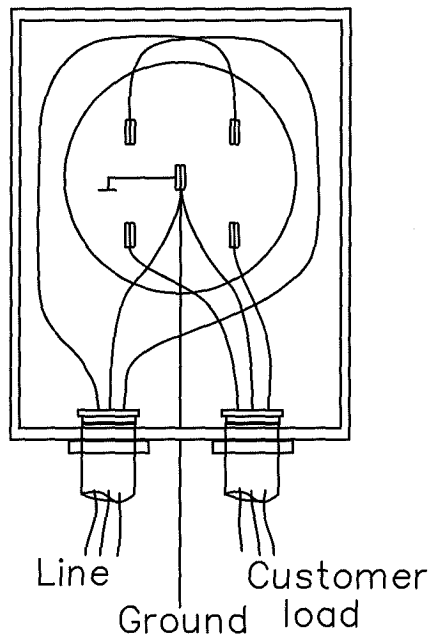

UNDERGROUND SERVICE
FIGURE 4-5b

SERVICE METERED USING DIRECT -CONNECT METERS

FOR SINGLE-PHASE SERVICES:

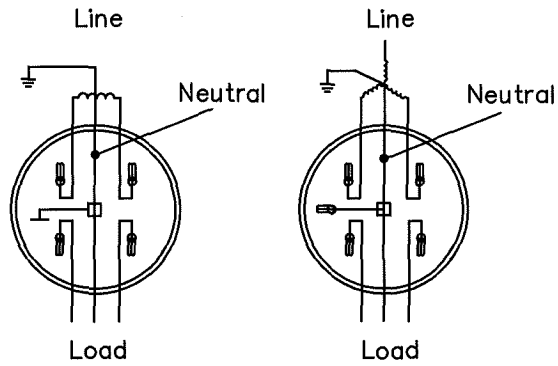

120/240V 3-WIRE
FIGURE 4-6a

120/208V 3-WIRE NETWORK
FIGURE 4-6b

FOR THREE-PHASE SERVICES:

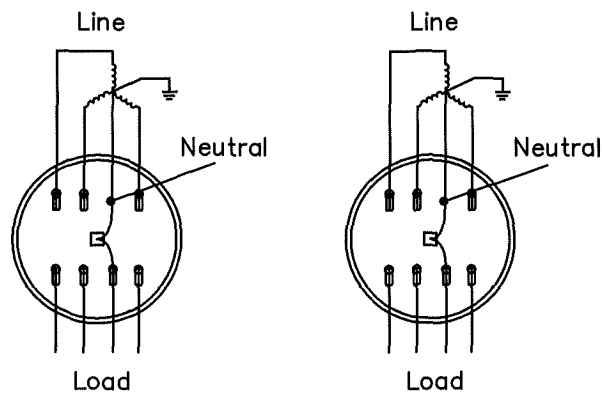

120/208V 4-WIRE WYE
FIGURE 4-6c

277/480V 4-WIRE WYE
FIGURE 4-6d

SERVICES METERED USING CURRENT TRANSFORMERS

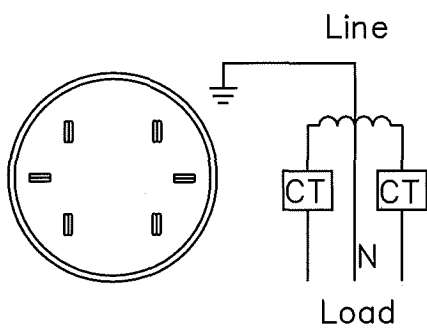

SINGLE PHASE
120/240V 3-WIRE
FIGURE 4-7a

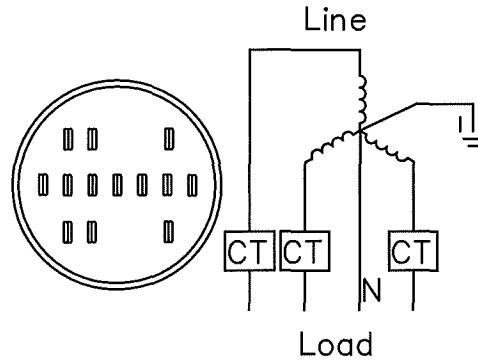

THREE PHASE
120/208V 4-WIRE WYE
FIGURE 4-7b

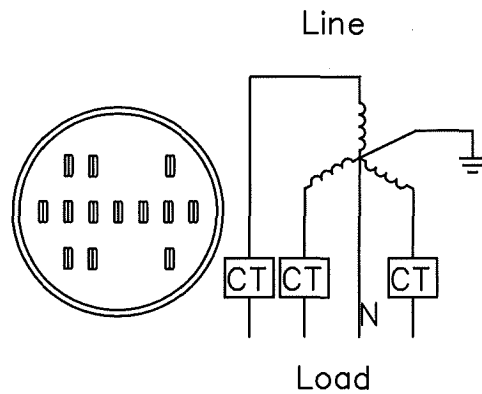

THREE PHASE
277/480V 4-WIRE WYE
FIGURE 4-7c

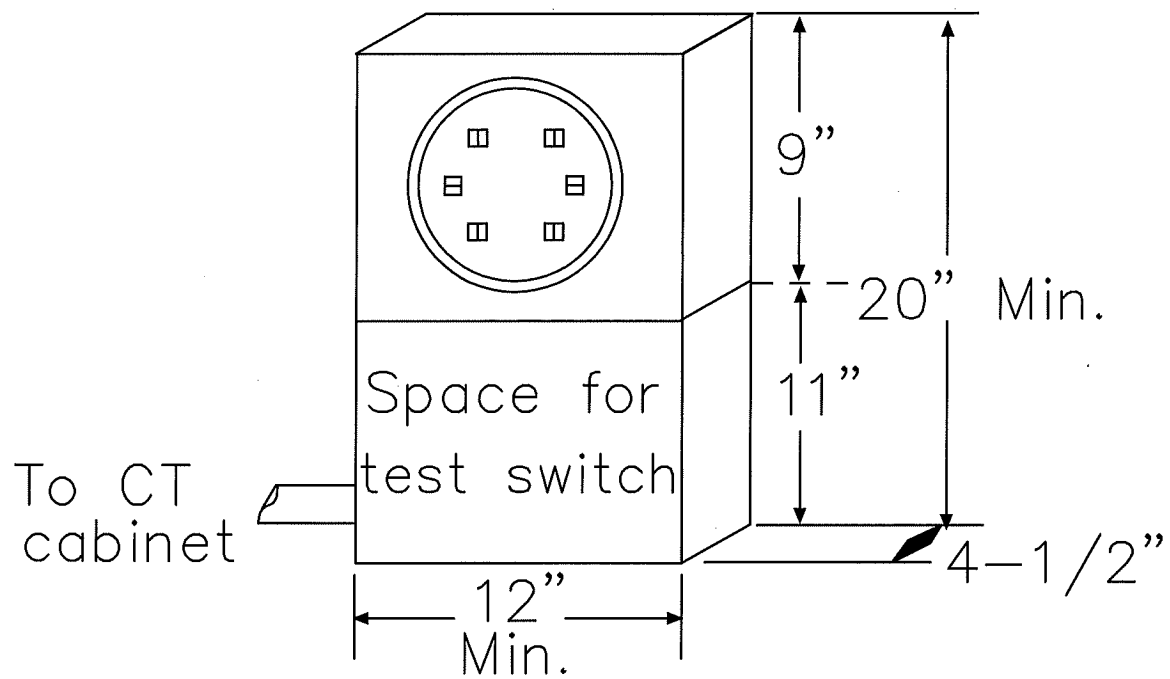

METER SOCKET AND ENCLOSURE
FOR SINGLE PHASE SERVICE USING CTs

FIGURE 4-8

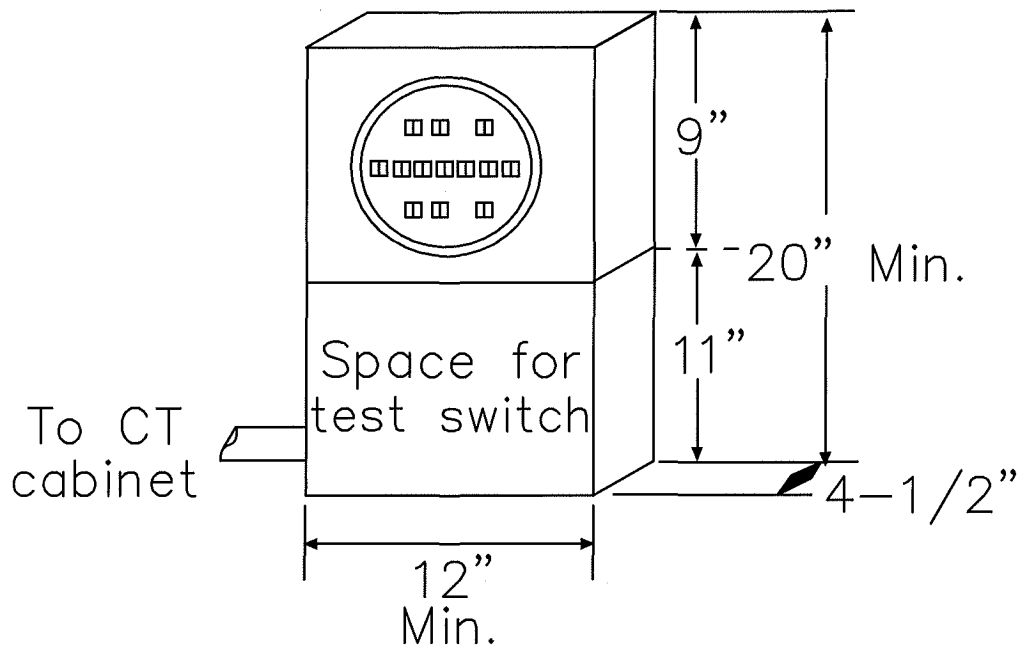

METER SOCKET AND ENCLOSURE
FOR THREE PHASE SERVICE USING CTs
FIGURE 4-9

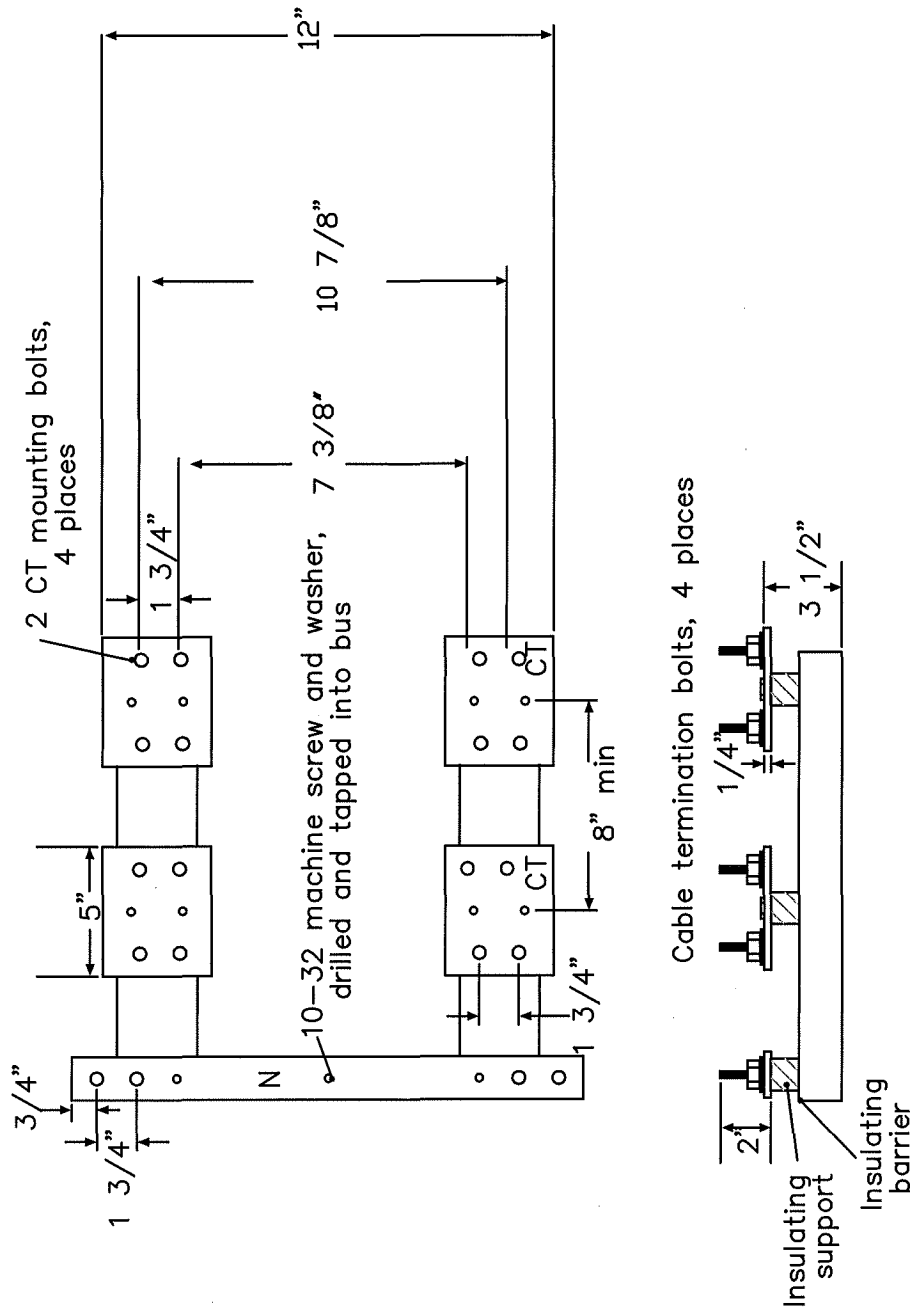

MOUNTING BASE FOR CURRENT TRANSFORMERS,
SINGLE PHASE SERVICE

FIGURE 4-10

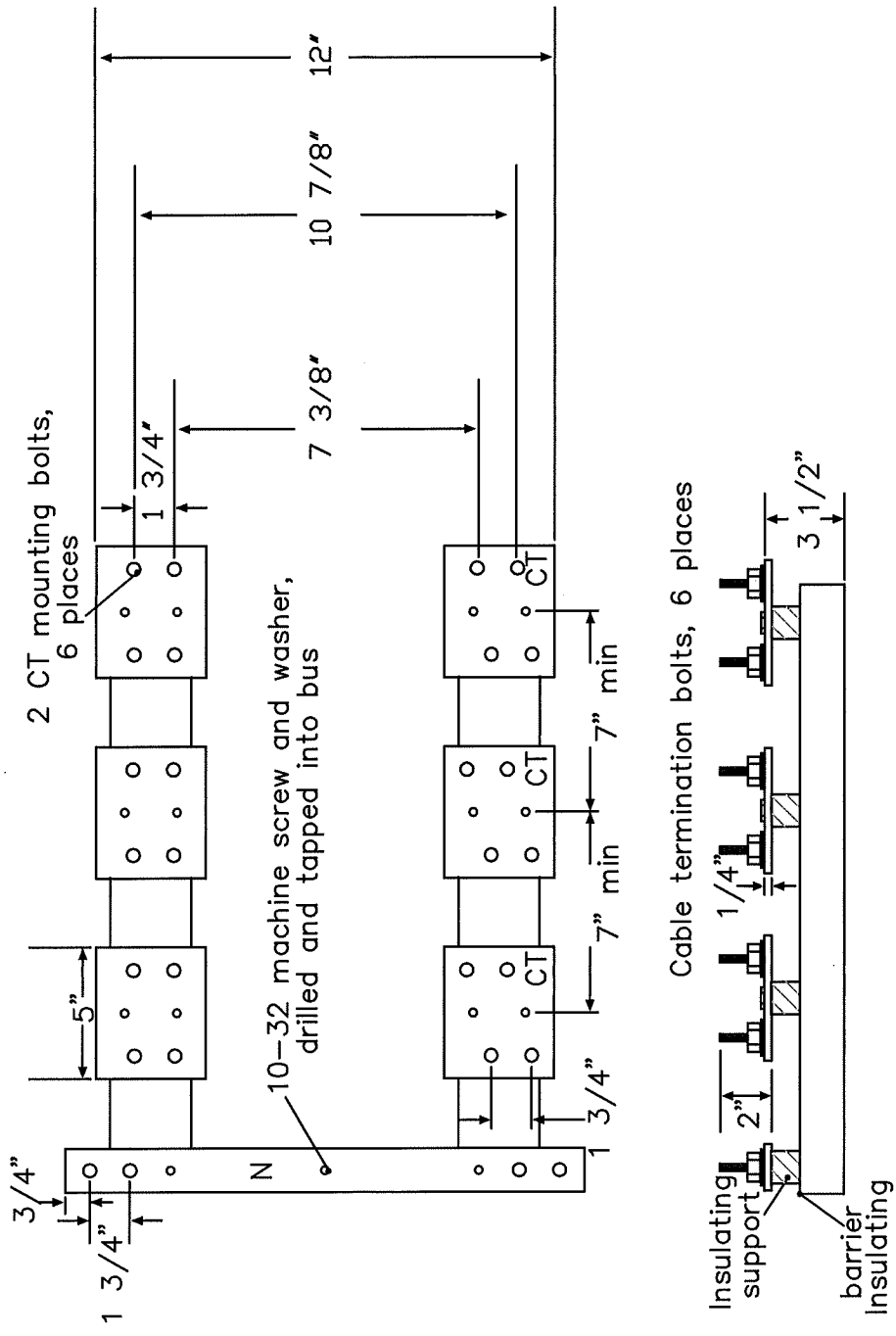

MOUNTING BASE FOR CURRENT TRANSFORMERS,
THREE PHASE SERVICE

FIGURE 4-11

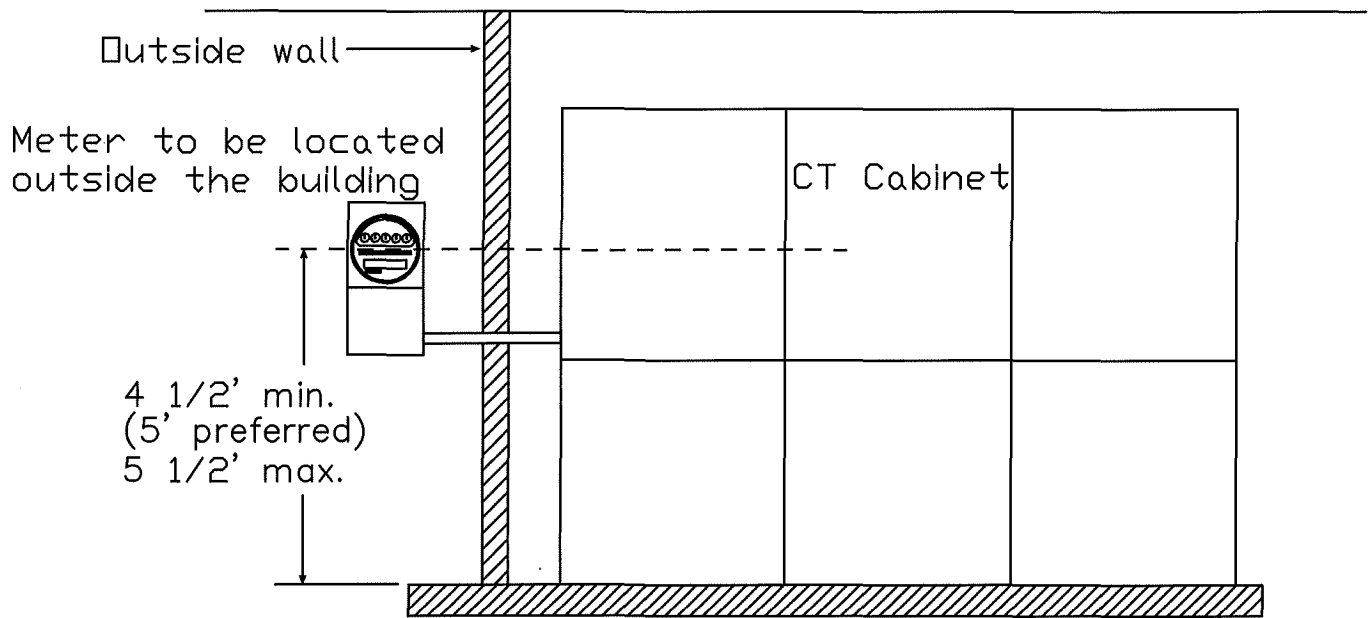

SWITCHBOARD METER INSTALLATION

FIGURE 4-12

120 240 SINGLE PHASE

HIGH CAPACITY
METER SOCKET
(6 TERMINALS)

SERVICE ENTRANCE
PANEL

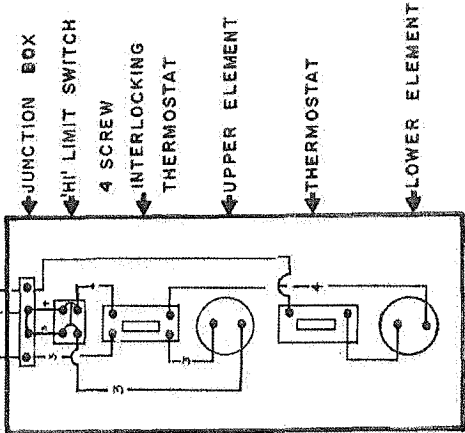

CHICOPEE ELECTRIC LIGHT
 725 FRONT ST. CHICOPEE, MA.

OFF-PEAK METER
 WIRING SPECIFICATIONS FOR A
 SINGLE METER APPLICATION

DRAWN BY: _____ SCALE: _____ DATE: _____
 CHECKED BY: _____

B -

FIGURE 4-13

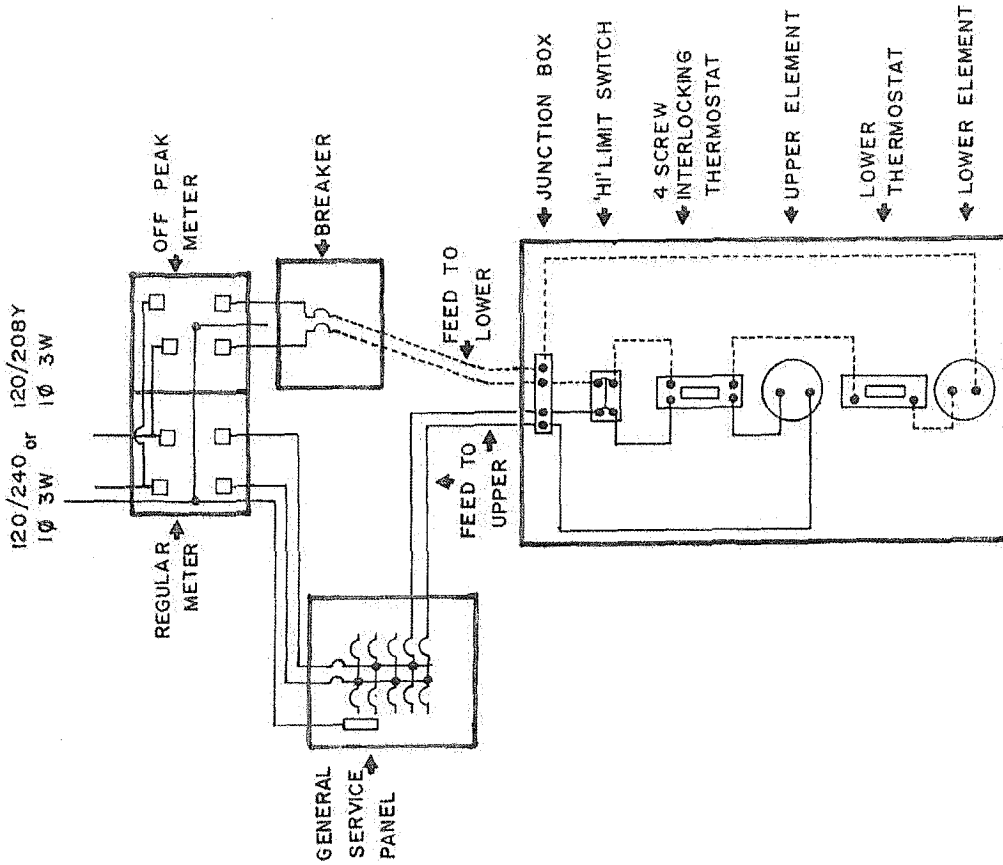

C-E-L
CHICOPEE ELECTRIC LIGHT

CHICOPEE ELECTRIC LIGHT
725 FRONT ST. CHICOPEE, MA.

OFF-PEAK METER
WIRING SPECIFICATIONS FOR A
TWO METER APPLICATION

DRAWN BY: _____ SCALE: _____ DATE: _____
CHECKED BY: _____

B-

FIGURE 4-14

CHAPTER 5

SERVICE FEE INFORMATION AND CUSTOMER FORMS

SERVICE FEE INFORMATION

UPDATED 09/21/2011

NON-PAYMENT RECONNECTION FEES

8:00 AM - 4:00 PM	Regular Reconnection Fee	\$50.00
8:00 AM - 2:30 PM	Regular Reconnection at Pole Fee	\$65.00
4:00 PM - 8:00 PM	Regular Reconnection Fee	\$135.00
2:30 PM - 8:00 PM	Regular Reconnection at Pole Fee	\$185.00

PAYMENT RELATED FEES

Non-Sufficient Fees (Returned Check) Fee	\$25.00
Stop Payment Fee	\$25.00

ELECTRIC SERVICE FEES

Temporary Electric Service Fees

<u>100 A Single Phase</u>	\$75.00
<u>200 A Single Phase</u>	\$100.00
<u>200 A Three Phase</u>	\$125.00
<u>Contract Work Service Disconnection</u>	\$50.00
<u>Contract Work Service Reconnection</u>	\$50.00
<u>Contract Light Pole Installation</u>	\$ 670.00
<u>Hold Utility Pole (2 hour min)</u>	\$65.00

Please Call Our Customer Service Representative at (413) 594-2400 For More Information or Other Fees and Charges That May Not Be Listed Above.

Contact CEL Engineering Department for all Other Service Charge Information.

Note: All Service Charges Must Be Paid Within 30 Days of Receipt.

CEL - Security & Contract Lighting Rental Rates (Effective June 1, 2011)

High Pressure Sodium (HPS) Fixtures:

100W Cobra Head	\$ 10.00/month
250W Cobra Head	\$ 14.00/month
250W Floodlight	\$ 15.00/month
400WCobra Head	\$ 22.00/month
400W Floodlight	\$ 22.00/month



Metal Halide(MH) Fixtures

250W Cobra Head	\$ 15.00/month
320W Cobra Head	\$ 18.00/month
400W Cobra Head	\$ 23.00/month
250W Floodlight	\$ 16.00/month
320W Floodlight	\$ 19.00/month
400W Floodlight	\$ 23.00/month
1000W Floodlight	\$ 36.00/month

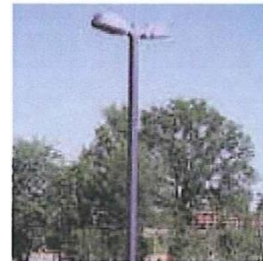

Contempo Mongoose Fixtures

250W HPS	\$ 16.00/month
250 MH	\$ 16.00/month
400W HPS	\$ 25.00/month
400W MH	\$ 25.00/month



LED Fixtures

48W or 50W Cobra Head	\$ 10.00/month
143W Cobra Head	\$ 14.00/month

Custom fixtures

All Custom Fixtures	Cost TBD
---------------------	----------

Pole Rental Charge (if required)

35' cl. Wood Pole	\$ 1.00/month
-------------------	---------------

Custom poles (concrete, aluminum, black aluminum, fiberglass, ect.) Cost TBD

\$ 670.00 per pole charge will be added upfront for each required pole installation

- To calculate your monthly total rental, add the fixture rental and the pole rental (if required).
- Minimum rental term is ten (10) years with a buyout option at CEL's discretion.
- Rental Agreement must be signed prior to installation.
- Custom fixture / pole / installation options are available and will be quoted on as needed basis.
- Customers who obtained rental contract or security lighting prior to June 1, 2002 will retain existing rates until further notice.

Sample Custom Fixtures



Traditionaire
(50-250W)

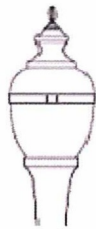

Westminster
(50-175W)



Concourse III
(70-400W)

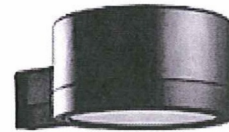

Cirrus
(50-1000W)

Important Terms & Definitions

Customer Charge	Customer Charge covers our cost to keep an electric account open-, inc_l_9i_9. . metering and billing. services, and is not dependent on the amount of electricity used.
Distribution Charge	Distribution is the local delivery of electricity to retail customers. This portion of the rate covers the cost to build and maintain the local electric system, including substations, transformers, poles, wires, as well as other consumer services.
Transmission Charge	Transmission Charge covers the utility's costs to move bulk electricity from power plants, over the transmission lines owned jointly by power plants and utilities, to local substations.
Generation Charge	Generation charge pays for the electric current produced at power plants. These cover two general categories of expenses: energy costs and capacity costs.
Purchase Power Adjustment	This is a difference between the average Purchased Power Cost for the given period and the Purchased Power Base Cost. It is calculated on an annual basis, as a charge or a credit, in order to levelize monthly fluctuations in power costs. This charge is reviewed regularly and can be modified to reflect changes in the markets.
Hydro Credit	Hydro Credit savings are passed to our residential customers as a benefit from the Niagara Hydro Project.
Primary Service	Primary Service designates customers owning high voltage equipment and taking energy with a demand of 100 KW or more.

Chicopee Electric Light Location & Hours

725 Front Street
Chicopee, MA 01021-0405
(413) 598-8311

Monday - Friday
Saturday - Sunday

8:00 AM - 4:30 PM
Closed

For more information, visit our Internet website at <http://www.celd.com>



CHICOPEE ELECTRIC LIGHT - Service & Meter Location Form

Service Address: _____

Property Owner: _____ Telephone No.: _____

Property Owner Address: _____

Service Type: Residential Commercial Industrial Heat Source: Electric Other

Service Size & Voltage: _____ Temporary Permanent

No. & Size of Service Conductors: _____ Overhead Underground

No. Of Meters: Existing _____ Proposed: _____ Requested Date: _____

MEC CMR 527 requires a licensed electrician perform all work and secure all inspections under Mass General Law 143. Service will not be connected until all inspections are performed and CEL has received approval notice from the City Wiring Inspector. CEL will not make permanent connections until all the above provisions have been satisfied.

Elect. Contractor's Name (print): _____ License No.: _____

Address: _____ Telephone No.: _____

Electricians Contact Name: _____ Date: _____

City Inspector's Permit No.: _____ Issue Date: _____

Comments: _____

NOTE - If CEL needs to respond to power quality issues (partial power, flickering lights, etc.) at the above address as a result of temporary connections, service fees will apply - \$55.00 during normal business hours / \$175.00 after hours

DO NOT WRITE BELOW THIS LINE

Service Work Type: New Change Addition Old Service Location: Indoor Outdoor

Located By: _____ Date: _____ New Service Location: Indoor Outdoor

Meter No(s). Installed: _____

Remarks / Comments/Special Instructions: _____

Wiring Inspector's Approval Date: _____ Completion Date: _____

CHICOPEE ELECTRIC LIGHT

Application for Temporary Service

STK# 10-03800



This application is a legal contract between the Applicant for utility services and the City of Chicopee Municipal Lighting Plant (CMLP).
(PLEASE PRINT CLEARLY) Application # _____

Today's Date _____ Date Service Requested _____ Length Required _____

Name _____ SSI/FID# _____

Service Taken on Behalf of _____

Service Location _____

Mailing address _____ City _____ State _____ Zip _____

Phone _____ Taken By _____

Previous / Current CMLP Customer: No Yes, Street address _____

TERMS & CONDITIONS

I HEREBY certify that the foregoing information is true and complete. I HEREBY also agree to abide by the Terms and Conditions set forth by CMLP of which I have been given a copy.

Signature _____ Date _____

Name (Print) _____ Company _____

CREDIT / DEPOSIT INFORMATION

I agree that CMLP may obtain information at any time from a consumer-reporting agency regarding my credit worthiness. Any information obtained by CMLP will not be disseminated to any third party without my permission. If CMLP takes any adverse action as a result of information contained in my report, CMLP shall furnish the name and address of the consumer-reporting agency making the report to me.

Signature _____ Date _____

OFFICE USE ONLY

Deposit \$ _____ Cash Check # _____ Surety Bond _____

Bank Letter of Credit _____ Payment Guarantee _____ Other _____

Taken by _____ Receipt # _____ Approved By _____

Account # _____ Debtor # _____

Disconnect Date _____ Final Bill Amount \$ _____

Mailing Address _____

Turned over to Collection Agency Yes No Date turned over _____ To _____

Remarks: _____

CHICOPEE ELECTRIC LIGHT



Residential Application for Service

STK# 10-03600

This application is a legal contract between the Applicant for utility services and the City of Chicopee Municipal Lighting Plant (CMLP).

(PLEASE PRINT CLEARLY)

Application # _____

Today's Date _____ Date to be Set _____ Taken by _____

Customers Name _____ SSI#/FID# _____

Service Location _____

Mailing Address _____ City _____ State _____ Zip _____

Phone _____ Emergency Phone _____

Previous / Current CMLP Customer: No Yes, Street Address _____

Employer's Name _____ Business Phone _____

Employer's Address _____ City _____ State _____ Zip _____

Nearest Relative _____ Phone _____ Address _____

Spouse / Co-signer _____ SSI#/FID# _____

Employer's Name _____ Phone _____

Landlord Name _____ Phone _____

Landlord Address _____ City _____ State _____ Zip _____

Are all residents 65 years or older: Yes No

Does Service Operate Life Support Equipment: Yes No

Type of Heat: Electric Gas Oil

Do you pay for Heating: Yes No

Type of Water Heating: Electric Gas Oil

Do you pay for Hot Water: Yes No

TERMS AND CONDITIONS

I HEREBY certify that the foregoing information is true and complete. I HEREBY agree to abide by the Terms and Conditions set forth by CMLP of which I have been given a copy.

Authorized Signature _____ Date _____

Co-Signer Signature _____ Date _____

CREDIT / DEPOSIT INFORMATION

I agree that CMLP may obtain information at any time from a consumer-reporting agency regarding my credit worthiness. Any information obtained by CMLP will not be disseminated to any third party without my permission. If CMLP takes any adverse action as a result of information contained in my report, CMLP shall furnish the name and address of the consumer reporting agency making the report to me.

Signature _____ Date _____

OFFICE USE ONLY

Residential Deposit \$ _____ Cash Check # _____ Other _____

Taken by _____ Receipt # _____ Approved By _____

Account # _____ Debtor # _____

Disconnect Date _____ Final Bill Amount \$ _____

Mailing Address _____

Turned over to Collection Agency Yes No Date turned over _____ To _____

Remarks: _____

CHICOPEE ELECTRIC LIGHT

Commercial / Industrial Application for Service

Page 1: STK# 10-03900 Must Also Order Page 2: STK#10-04000



This application is a legal contract between the applicant for utility service and the City of Chicopee Municipal Lighting Plant (CMLP).

(PLEASE PRINT CLEARLY)

Application # _____
Today's Date _____ Date Service Requested _____ Taken by _____
Name _____ SSI/FID# _____
Telephone No _____ Year Founded _____ Business Description _____
Service Location _____
Mailing Address _____
Previous / Current CMLP customer No Yes: If yes, at what address _____

If property is rented, name of owner _____
Address _____
If property is owned, name on property deed _____
Type of Heat: Gas Oil Electric
Type of Hot Water: Gas Oil Electric

Chief Financial Officer _____ Phone _____
Chief Executive Officer _____ Phone _____
President _____ Phone _____
In case of an emergency please contact _____ Phone _____

PLEASE COMPLETE THIS INFORMATION

SOLE PROPRIETOR / PARTNERSHIP: (If more than two partners, please attach)

First Owner's Name _____ SSI# _____
Address _____ Phone _____
City _____ State _____ Zip _____

Second Owner's Name _____ SSI# _____
Address _____ Phone _____
City _____ State _____ Zip _____

CHECK ONE OWNERSHIP: Public Private Foreign Non-Profit
OWNERSHIP TYPE: Corporation Partnership Sole Proprietor S Corporation
LOCATION TYPE: Branch Franchise Division Subsidiary Single Location

Latest Year's Sales Volume \$ _____ Latest Year's Profit \$ _____ Net Worth \$ _____
Number of Employees _____ Sales Tax Exempt: No Yes (Exemption Form Required)
Exempt Basis: Manufacturing Less than 5 Employees Non-profit

HOME OFFICE OR PARENT COMPANY (IF APPLICABLE)

Company Name _____ Phone _____
Address _____ City _____
State _____ Zip _____ State of Incorporation _____

Your electric bill now has a new, easy-to-read format.

DETACH this top section and INCLUDE with your payment each month.

The address where electricity is used.

Payment due date.

Amount due.

Your personal account number.

Your actual electric usage since the last meter reading.

Your name and address.



JOSEPH SMITH
107 N WASHINGTON STREET
CHICOPEE, MA 01020

Customer Account Number		
000-00000000-000		
Due Date	Amount Due	Amount Enclosed
12-22-2003	37.20	
Service Address		
107 N WASHINGTON STREET		

Check here if providing information on the back

000000000000000000000000000000

Please detach top portion and return with payment.

Dates of previous and current meter readings.

Our meter number.

Account activity shows detailed transactions, which occurred since your last bill.

Your electric usage history for the past year, broken down by number of total days, total electricity consumed, and average kilowatt-hour per day, which you have used each month.

Chicopee Electric Light	Account Number 000-00000000-00	Name JOSEPH SMITH	Service Address 107 N WASHINGTON STREET				
Meter Number	Read Dates	Billing Days	Meter Readings	Multiplier	Usage	Units	Power Factor
	Present Previous		Code Present Previous				
ELECTRIC: 0000003893	11-17-2003 10-20-2003	28	MR 0453 0058	1	395	kWh	

BILLING SUMMARY	
Previous Balance:	\$37.59
Payments & Adjustments:	\$-37.59
Balance Forward as of: 11-25-03	\$0.00
Current Charges as of: 11-25-03	\$37.20
Total Amount Due:	\$37.20

PREVIOUS BALANCE	37.59
PAYMENT 11-05-2003	-37.59
BALANCE FORWARD	0.00
CURRENT CHARGES / CREDITS	
DELIVERY SERVICES	
DISTRIBUTION / ACCESS CHARGE	20.42
CUSTOMER CHARGE	6.00
TRANSMISSION CHARGE	1.94
SUPPLY SERVICES	
GENERATION CHARGE	11.06
HYDRO CREDIT	-2.22
CURRENT CHARGES	37.20
TOTAL AMOUNT DUE	37.20

USAGE HISTORY					
Month	Days	Electric Use (kWh)	Elec. Usage Per Day	KVA / KW Demand	Power Factor
11-03	28	395	14		
10-03	32	400	13		
09-03	30	570	19		
08-03	29	739	26		
07-03	34	816	24		
06-03	32	461	14		
05-03	31	431	14		
04-03	28	460	16		
03-03	28	554	20		
02-03	32	539	17		
01-03	31	570	18		
12-02	28	447	16		
11-02	29	370	13		

This data is shown only for our business accounts.

Chicopee Electric Light www.celd.com
725 Front Street, Chicopee, MA 01020-0405 413-598-8311 FAX: 413-594-5507

Bill Type	Account Type	Bill Date	Due Date	Amount Due	Past Due
REGULAR	RESIDENTIAL	11-25-2003	12-22-2003	37.20	\$0.00

MESSAGES:

DELIVERY SERVICES:

Distribution / Access Charge - the cost of delivering electric energy to you by CEL's facilities.

Customer Charge - the cost of providing related services, such as metering, meter reading and billing, which are independent of the actual amount of electricity you use.

Transmission Charge - the cost of using the transmission grid to deliver electric energy from generating units to the CEL's distribution system.

SUPPLY SERVICES:

Generation Charge - the cost of electrical energy produced by the generators, who sell this energy to CEL.

Hydro Credit - these savings are passed on to all residential customers as a benefit from the St. Lawrence and Niagara Hydro Projects. Hydro Credit is applied to all kWh's used.

This special comment area is reserved for special messages from CEL to you.

This is when your electric bill was issued.

Payment must be received by CEL by this due date.

Total amount you must pay by the due date.

GLOSSARY

ANSI	American National Standards Institute. An independent administrator and coordinator of voluntary industry standards
Bypass	A device which shunts current around the socket, so the meter can be removed without interrupting service
Clearance	There are two, quite different meanings for "clearance." One meaning is: A specified minimum distance between two objects to assure adequate space for safety, security, or access. The other meaning is: An agreement between a foreman and the system operator, for permission. When describing new electric services, "clearance" has the first meaning the distance between two objects.
Common Ground Point	The point where the grounding electrode connects to the equipment-grounding conductor and / or the circuit-grounding conductor
Conduit	A pipe with a smooth interior surface for easy drawing-in of electrical conductors. Conduit may be metallic or nonmetallic
Corrosion Inhibitor	An electrical joint compound used to retard oxidation at electrical connections
Current Transformer	A transformer whose secondary current is a precise fraction of its primary current. Using current transformers, high-current circuits can be measured with conventional meters. Abbreviation: CT.
Demand	The average rate at which energy (kilowatt hours) is consumed during a specified interval of time.
Direct-Burial Cable	Cable that may be installed in the ground without the protection of a conduit.
Direct Connect Meter	A meter that carries full load current and connects across full line voltage. Also called a self-contained meter.
Drip Loop	A downward loop in the customer's conductors, near where the customer's conductors attach to the power company's overhead conductors, to prevent water from entering the service mast at the weatherhead.
Fault	A partial or total failure of insulation that causes a short circuit between conductors, or between a conductor and ground, causing an abnormal current to flow. Also, a failure in a conductor that causes an open circuit.
Fault Current	A current that flows between conductors, or between a conductor and ground, due to an abnormal connection between the two. A fault current flowing to ground may be called a ground fault current.

GLOSSARY

Guy	A cable or brace that supports a mast or pole
High Leg	In a four – wire delta service, the phase with a voltage higher than the other two phases. Also called wild leg, delta leg.
Instrument Transformer	A transformer that delivers as its output, a precise fraction of the input line current or line voltage. Instrument transformers allow standard meters to measure high currents and voltages.
Instrument-rated meter	A meter used in conjunction with instrument transformers, to measure high-voltage or high current services. Also called a transformer-rated meter.
Line Conductor	A service conductor installed by the electric utility, to the meter.
Load Conductor	A service conductor to the customer’s load, after the meter.
Manual Link Bypass	Provision for manually installing conductive links between the line and load terminals in the meter socket. These links maintain electrical service to the customer when the meter is removed. Also called manual circuit-closing block.
Manufactured Home	A factory-assembled structure built on a permanent chassis, transportable in one or more sections, and designed to be used as a dwelling with a permanent foundation. Also called a modular home. New electric service to a manufactured home has the same requirements as installing new service to a permanent single-family residence.
Mass. Electric Code (MEC)	State regulations for the installation of electrical equipment inside buildings. MEC rules apply to equipment on the customer’s side of the point of delivery.
Meter Jaw	A spring-loaded receptacle inside a meter socket that captures the terminals (blades) of a meter, and connects the meter terminals to the service conductors.
Meter Pedestal	A factory-built assembly containing a meter socket and disconnect switches.
Meter Ring	A metal ring that secures the meter to the meter socket, which can be sealed by the electric utility to prevent tampering with the meter.
Meter Socket	The mounting device consisting of meter jaws, connectors, and enclosure for receiving a socket-type meter.
Mobile Home	A factory-assembled structure built on a permanent chassis, transportable in one of more sections, and designed to be used as a dwelling without a permanent foundation. Underground service to a mobile home is provided by a meter pedestal.

GLOSSARY

NEC	National Electrical Code. National regulations for the installation of electrical equipment inside buildings. Published by the National Fire Protection Association. NEC rules apply to equipment on the customer's side of the point of delivery.
NEMA	National Electrical Manufacturers Association. A trade association which publishes standards for manufacturers of electrical equipment, including enclosures, and racks.
NESC	National Electrical Safety Code. National regulations for the installation, operation, and maintenance of electric supply and communication lines. Published by Institute of Electrical and Electronics Engineers. NESC rules apply to equipment on the electric utility's side of the point of delivery.
Neutral	The grounded conductor in a single-phase three wire, or three-phase-four-wire system.
Points of Attachment	The point at which the utility's service conductors are mechanically attached to the customer's premises. For overhead services, the point of attachment is usually an insulated clevis.
Point of Delivery	The point where the utility's service line makes the electrical connection to the customer's wires. For overhead services, the point of delivery is the splice between the utility's and the customer's conductors. For underground services, the point of delivery is the secondary lugs of the distribution transformer, or the service stubout, or the secondary hand hole – if the utility's existing service is on the customer's property. If the utility's existing service is not on the customer's property, the point of delivery is the customer's property line. The utility determines the point of delivery based, in part, on convenient access to existing service.
Power Factor	Technically, the cosine of the phase angle between the circuit voltage and current waveforms. Since phase angles are difficult to measure, power factor is usually derived by measuring power or impedance. Power factor is the ratio of active power to apparent power (watts divided by volt-amperes). Power factor has no units, but is commonly expressed as a percentage. For example, if active power is 96 kW and apparent power is 100 kW, the power factor is 96%.
Primary Voltage	The voltage at which electricity is delivered from substations to distribution transformers. Primary voltage is greater than 600 volts.
Raceway	An enclosed channel for holding wires or cables. If designated for line conductors, the raceway must be sealable. The intermixing of line and load conductors in the same raceway is not permitted.
Seal	A locking device to secure a meter or other service equipment.

GLOSSARY

Secondary Voltage	The voltage at which electricity is delivered from distribution transformers to customers. Secondary voltage is less than 600 volts.
Select Backfill	Soil or sand free from sharp objects, rocks, scrap building material, and corrosive material.
Self Contained Meter	A meter that carries full load current and connects directly across full line voltage. Also called a direct-connect meter.
Service Drop	For overhead service, the power company's service line between the utility pole and the point of delivery.
Service Line	Conductors from the distribution transformer to the customer's point of delivery. See service drop, service lateral.
Service Entrance Equipment	The service equipment which is supplied by the customer: conduit, conductors, mast, weatherhead, meter base, enclosures, disconnects, and panels.
Service Lateral	For underground service, the service line between the distribution transformer and the point of delivery.
Service Mast	For overhead service, the conduit rising above the meter to provide mechanical protection to the customer's conductors and to support the service drop from the power company.
Socket	The mounting device for socket meters. Includes spring-loaded meter jaws, connectors for line and load conductors, and an enclosure.
Temporary Service	Electric service during the construction phase of a project.
Test Switch	A device used to isolate connections to a meter from its instrument transformers.
Transformer-Rated-Meter	A meter used in conjunction with instrument transformers, to measure high-voltage or high-current services. Also called an instrument-rated meter.
UL	Underwriters Laboratories. An independent product-testing and certification organization.
Voltage Transformer	A transformer whose secondary voltage is a precise fraction of its primary voltage. Using voltage transformers, high-voltage circuits can be measured with conventional meters. Abbreviation: VT, or PT (potential transformer).